

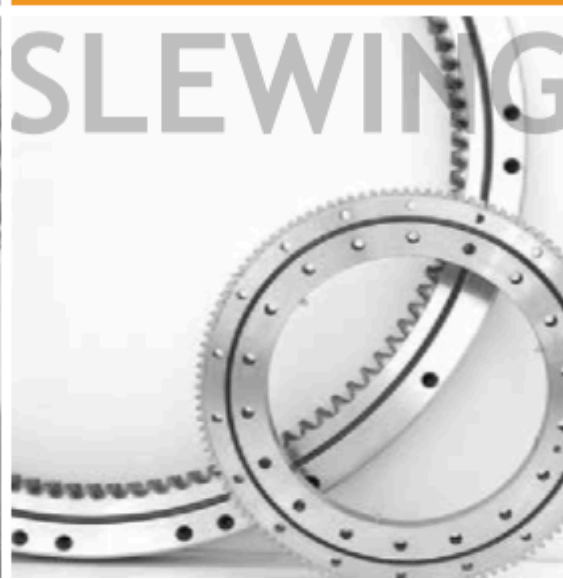

tibett  
Makina Sanayi ve Tic.A.Ş.





arbak  
Grup

# İÇİNDEKİLER / CONTENTS

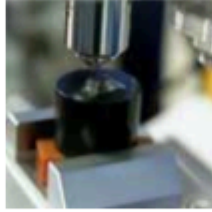
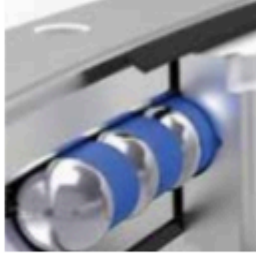

Biz kimiz? / Who We Are? .....	2-3
Vizyon & Misyon / Vision & Mission .....	4-5
AR-GE / Research & Development.....	6-7
Kalite / Quality .....	8-9
Sertifikalar / Certificates .....	10
Test Cihazları-Ölçü ve Kontrol Ekipmanları / .....	12-13
<i>Test Equipments-Dimension Measurement and Control Test</i>	
Üç Boyutlu Koordinat Ölçme Cihazı / .....	14
<i>Gantry Coordinate Measuring Machine</i>	
Döner Tabla Dişlileri ve Rulmanları / .....	16
<i>Slewing Rings and Bearings</i>	
a. İmalat Yöntemi / Process of Production .....	17
I. Ham Madde / Raw Materials .....	19
II. Kaplama / Coating.....	20-21
III. Montaj / Mounting.....	22
IV. Sertlik Aralığı / Hardness Range .....	23
V. Pinyon / Pinion .....	24
VI. Ambalajlama Depolama ve Nakliye / .....	25
<i>Packaging, Storing and Shipment</i>	
Uygulamalar / Applications .....	26-27
Yağlama ve Bakım / .....	28
<i>Lubrication and Maintenance</i>	
Hesaplamalar / Calculations .....	29
Kod Bilgi Sistemi / .....	29
<i>Drawing Number Composition</i>	
Yatak Seçim Bilgi Formu / .....	30
<i>Information Form of Bearing Choice</i>	
Ürünler / Products.....	32-53
Tek Sıra Küresel Bilyalı Profil Yataklar (L Tipi) / .....	32-35
<i>Single - Row Ball Profile Bearings (Type L)</i>	
Tek Sıra Küresel Bilyalı Yataklar (4 Noktalı Yataklar) .....	36-39
<i>Single Row - Ball Bearings (4 Points Contact Bearings)</i>	
Çift Sıra Küresel Bilyalı Yataklar / .....	40-43
<i>Double - Row Ball Bearings</i>	
Tek Sıra Masura Yataklar / .....	44-47
<i>Single - Row Roller Bearings</i>	
Üç Sıra Masura Yataklar / .....	48-51
<i>Three - Row Roller Bearings</i>	
Tel Yataklar / Wire Race Bearings .....	52-53

Tüm bilgiler TİBET MAKİNA'ya aittir izinsiz kullanılamaz, yayınlanamaz.  
TİBET MAKİNA tüm değişiklik haklarını saklı tutar.

*All rights reserved. Printing and references without permission, are prohibited.  
The specifications may change without prior notice due to continuous produced improvements.*

## ■ BİZ KİMİZ?

TİBET MAKİNA 1970 yılında Temuçin Arbak tarafından İzmir'de kuruldu. İlk yıllar otomotiv, toprak ve deri sektörlerine yedek parça üretimi yaptı. İlerleyen dönemlerde ağır makine sanayine hizmet etti.

80'li yıllara gelindiğinde Türkiye'de ilk ekskavatör üretiminin başlamasıyla, talepler doğrultusunda kule dönüş dişlilerini üretmeye başladı.

1990 yılında üretimini ve yatırımlarını bu yönde yapma kararı aldı. 1996 yılında Menemen tesislerinin temellerini attı.

1998 yılından beri, Menemen'de 4500 m<sup>2</sup> kapalı olmak üzere, toplam 15,600 m<sup>2</sup> lik yeni tesislerinde, yatırımlarını artırarak üretimine devam ediyor.

İş makineleri, lunapark makineleri, şişeleme dolum tesisleri, demir çelik sanayi, vinç sanayi, savunma sanayi, rüzgâr türbinleri başta olmak üzere farklı birçok sektöre hizmet vermektedir. TİBET MAKİNA artan kalite hedefleriyle üretim kapasitesini paralel bir şekilde yükselterek büyümeye devam etmektedir. Bugün üretiminin %40'ını yurtdışına ihraç eden firma, dünya devlerine hizmet vermenin gururunu taşımaktadır.





## WHO WE ARE?

*TİBET MAKİNA was established in 1970, in İzmir Turkey by Temuçin Arbak.*

*Following several years of its establishment it supplied spare parts to the automotive industry and leather industries.*

*It supplied to heavy industry at later periods.*

*In 1980s, excavator production has begun in Turkey, TİBET MAKİNA started to produce slewing ring according to demands.*

*In 1990, the company channeled its entire production in this way. In 1996 the company started to built its present facility at Menemen.*

*From 1998 new facility including 4500 m<sup>2</sup> in door area, totally 15600 m<sup>2</sup> at Menemen has been keeping production with increasing its investment.*

*Serving different industries, including;*

*Construction equipment, funfair equipment, bottling and filling plants, iron and steel plants, gantry crane and mobile crane, defence system, wind turbines. TİBET MAKİNA keeps quality target extending parallel to manufacturing capacity.*

*Exporting 40% of production, takes justified pride at service to world's giant companies.*

## VİZYON-MİSYON

Dışli ve rulman sektöründe, hem yurtiçi hem de yurtdışı piyasasında kaliteli ürünleri, zamanında teslimatları ve müşteri memnuniyetini kendine ilke edinmiş personeli ile sürekli gelişmeyi hedefleyen örnek ve lider bir kuruluş olmak.



- Ticari, ahlaki, hukuki kurallara saygılı olmak,
- Dinamik bir organizasyon yapısına sahip olmak,
- Bilgi, tecrübe ve yaratıcılığa dayalı kaliteli üretim anlayışımızla kalıcı ilişkiler kurmak,
- Sektöründe en ileri teknolojiyi takip etmek,
- Sosyal ve ekonomik değer yaratarak ülke ekonomisine katkıda bulunmak,
- Müşterilerimiz, tedarikçilerimiz, çalışanlarımız ve ülkemiz için sürekli fayda yaratmak.

Toplam Kalite Yönetimi felsefesini ve sürekli gelişim anlayışını ilke edinerek, bu yolculukta devamlı mesafe katetmek.

## VISION-MISSION

The vision of TİBET MAKİNA is to have continuous development with staff member whose principle is customer's satisfaction, to be a leader with producing quality gears and bearings at domestic and foreign market on delivery time.



- To respect commercial rules, precepts and legal rules
- To have dynamic organization
- To build permanent relations using with knowledge, experience, creativity
- To follow up most advanced technology at industry
- To make an economic contribution at national economy with creating social and economic value
- To gain favor for our customers, suppliers, employees and country.

Therefore, take as principle total quality management and perception of continuous development to advance continuously in this journey.

*Medeniyetin yapı taşı...  
The most important element of civilization...*





## AR-GE

AR-GE departmanı genel olarak müşteriden gelen taleplere göre SolidWorks çizim programını kullanarak ürünleri 3 boyutlu olarak çizmektedir. Müşteriden gelen ürün, yük bilgileri veya teknik resim ve şartname bilgileri doğrultusunda ürün imalat resmi hazırlanarak ön çalışması tamamlanır. Dişli çalıştırma simülasyonu programı olan GearTrax ile; DIN, PGT, British Standard, JIS, Coarse Pitch Involute, Fine Pitch Involute, Stub Involute standartlarında modül veya Diametral pitches olarak dişliyi imalata uygun gerçek diş evolvent eğrileri ile modeller.

Ürünlerin gerçek ölçülerinde çizilmesi ve simüle edilmesi ile de bilgisayar ortamında doğrulanması sağlanmış olur. Ürünlerin yük diyagramları hazırlanarak yük-moment grafiği çizilir.

SolidWorks S.P kullanarak, ürünlerin gerçek ortam koşullarında analizi yapıldığı için, prototip imalatı ve testler açısından maliyetler en aza **indirilir**.

Müşterilerimizin istemiş oldukları ürünler bilgisayar ortamında simüle edilerek Statik, Frekans, Burkulma, Basınç ve Termal analizleriyle birlikte; düşme ve yorulma testleri Solid Works S.P. programı kullanılarak yapılmaktadır.

**TİBET MAKİNA AR-GE ekibi tecrübesi, konusunda uzman ve genç kadrosuyla tekliflendirme sürecinden, imalat aşamasına kadar her türlü soruna profesyonel çözümler sunmaktadır.**

### AR-GE' de kullanılan programlar:

- 1- 3D Cad Dizayn programı ( Solid Works)
- 2- 2D Cad Dizayn programı (Autocad)
- 3- Sonlu elemanlar metodu ile analiz programı (Solid Works Simulation)
- 4- 3D Cam programı (Solid Cam)
- 5- Dişli çalıştırma simülasyonu programı (GearTrax)
- 6- ERP programı (Dinamo)



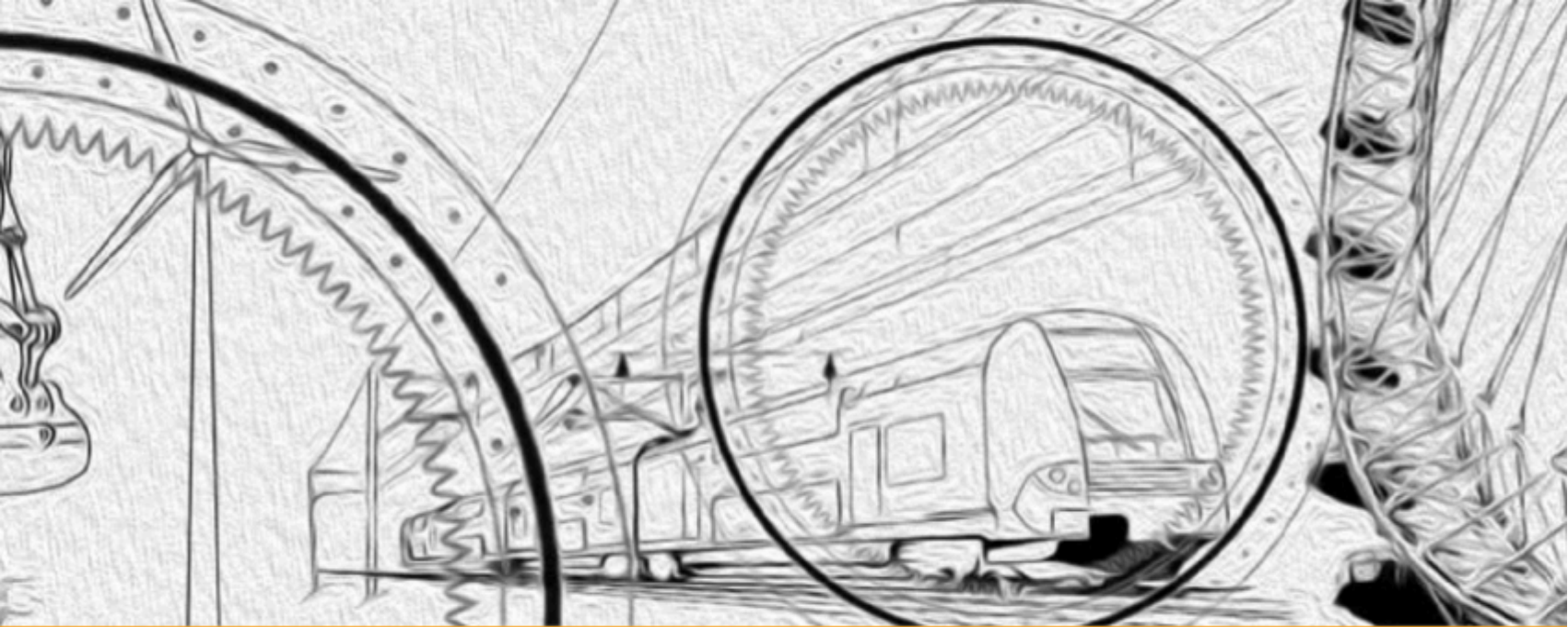

## RESEARCH & DEVELOPMENT

*To prepare 3D solid model using with SolidWorks according to our customers' demand*

*To prepare drawing according to customers' product, load data or technical drawing and specifications.*

*To simulate gear actual involute curve at DIN, PGT, British, JIS, Coarse Pitch Involute, Fine Pitch Involute, Stub Involute standards according to manufacturing; using with GearTrax which is gear simulation program*

*To verify gear dimensions while modelling gear with pc programs and creating load-moment diagrams*

*To resolve strength analysis at actual conditions using with SolidWorks S.P for producing prototype and reducing test costs*

*To resolve static, frequency, buckling, pressure, thermal analysis and fatigue, drop tests using with SolidWorks S.P. according to our customers' demand*

*On the upshot; TIBET MAKINA R&D team of experts is able to provide professional solutions for each problems from bid process to manufacturing process*

### **PC Programs at R&D Department are:**

- 1- 3D Mechanical Cad Program (Solid Works)
- 2- 2D Mechanical Cad Program (Autocad)
- 3- Finite Element Analysis Method Program (Solid Works Simulation)
- 4- 3D Cam Program (Solid Cam)
- 5- Gear Run Simulation Program (GearTrax)
- 6- ERP Program (Dinamo)

Şirketimizin amacı; kalitemizi artırarak ve maliyetlerimizi düşürerek uluslararası piyasalarda rekabet şansımızı artırmak ve pazar payımızı genişletmektir. Tüm çalışanlarımızın katılımı ve inanca çalışmalarıyla imalat, satış ve sonrası hizmetlerimizde;

- Müşterinin ihtiyaçlarını tam ve zamanında en ekonomik şekilde karşılamak,
  - Şirketimiz ve müşteri arasında güçlü bir iletişim sağlamak,
  - Müşterinin şikayetsiz beğenisini sağlamak,
  - Zamana bağlı nümerik hedeflerle çalışmak,
  - Eğitimi önemsemek, personelin kalite bilinci ve ekip çalışması anlayışını geliştirmek,
  - Çalışanlarımızın motivasyonunu sağlamak ve iş ile ilgili sorumluluk bilincini geliştirmek,
  - Şirketimiz çalışanlarının, iş sağlığı, iş güvenliği ve çevrenin korunmasında sorumlu olup bunları en az maliyet ve kalite kadar önemsemelerini sağlamak,
  - Mevcut kaynakları etkin kullanmak,
  - Sürekli iyileştirme ve gelişme bilinci ile hareket etmek,
- başlıkları ile belirlediği politikasını; uygulama, izleme, devam ettirme ve geliştirme gereğinin bilinci ve kararlılığı ile uygular.



Bu amaçla verilen hizmetlerin, firma politika ve hedeflerine, müşteri beklentilerine, kalite sistem standartlarına ve yasal düzenlemeye uygun olarak gerçekleştirilmesi için gerekli olan faaliyetleri organize etmeyi, kaynakları sağlamayı ve önlemleri almayı taahhüt eder.

Firma organizasyon yapısını, yetki ve sorumlulukların dağılımını bu amaçlara uygun olarak düzenler. Üretim ve hizmetlerin zamana bağlı performansını; yönetim, belirli periyotlarla gözden geçirme toplantıları ve yönetim temsilcisi tarafından hazırlanan raporlar çerçevesinde değerlendirir. Sonuçlara bağlı olarak gerekli önlemleri alır, politika ve hedefleri günceller.



## ■ QUALITY

*It is the purpose of our company to increase our competition opportunity and to enlarge our market share in international markets by means of increasing our quality and decreasing our costs. Our company acts with the consciousness and determinedness of the necessity to implement, monitor, pursue and develop a policy determined by the same under the following headings in our manufacturing, sales and after-sales services together with the participation of all our employees and their believing operations:*

- Meeting the customer needs on a full and timely basis and in the most economic manner,*
- Procurement of a good communication between our company and customers,*
- Procurement of the appraisal of the customer without any complaints,*
- Working for time-dependent numerical targets,*
- Paying attention to the training as well as the development of the quality consciousness and team work understanding of the personnel,*
- Procurement of the motivation of our employees as well as the development of the responsibility consciousness related with the business,*
- Procurement that the employees of our company are responsible for the health of employees, security at work and protection of the environment and they pay attention to the same just as much as they pay attention for cost and quality,*
- Efficient use of the existing sources,*
- Acting with continuous improvement and development consciousness.*

*TİBET MAKİNA undertakes to organize the necessary activities, to procure the sources and to take the precautions in order for the services rendered for this purpose to be realized in compliance with the policies and targets of the company, expectations of the customers, quality system standards and legal regulations.*



*For this purpose, the company regulates its organization structure and the distribution of its authorities and liabilities in an appropriate manner. At certain intervals, the company evaluates the time-dependent performance of the manufacturing and services within the framework of management revision meetings and reports drawn up by the management representative.*

*The company takes the necessary precautions in a manner founded upon the results and updates its policies and targets.*

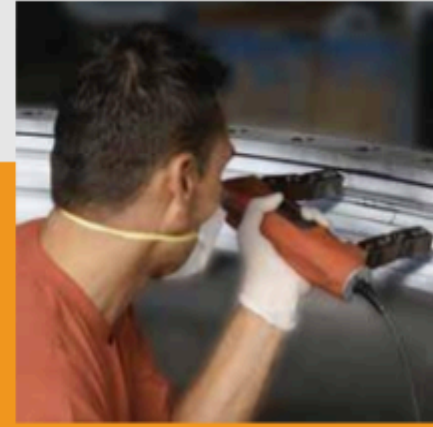
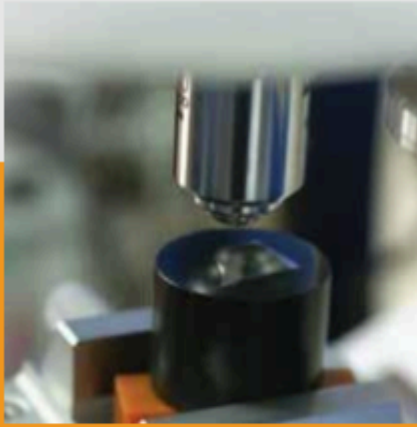

**YAPILMAYA DEĞER ŞEYLER, KALİTELİ YAPILMAYA DA DEĞER**  
**THINGS WORTH TO DO IS WORTH TO BE DONE IN QUALITY**

## SERTİFİKALAR / CERTIFICATES





*Denizlerin yükselen değeri...*  
*The rising value of ocean...*

## TEST CİHAZLARI

- Sürtünme torku test cihazları (0-25 °C)
- Yüksek sıcaklık testi (+55° C)
- Düşük sıcaklık testi (-32° C)
- Bağıl nem test cihazı (sıcaklık ve nem kontrollü)
- Yağmur testi
- Hava sızdırmazlık testi
- Su sızdırmazlık testi
- Eğilme testi
- Axial yük testi
- Radyal yük testi
- Su testi
- Axial ve radyal yük testi
- Radyal öz katılık testi
- Boşluk kontrol testi

## ÖLÇÜ VE KONTROL EKİPMANLARI

- DEA delta slant performance 3 boyutlu koordinat ölçme cihazı 3000x5200
- Romer marka portatip 3 boyutlu ölçüm cihazı
- METKON bakalite (kalıba) alma cihazı
- METKON zımpara ve parlatma cihazı
- METKON disk kesme cihazı
- TIME TR 200 yüzey pürüzlülük ölçüm cihazı
- TIME TT 260 kaplama kalınlığı ölçüm cihazı
- HM-112 micro vickers sertlik ölçüm cihazı
- Equotip-3 brinnell - rockwell sertlik ölçüm cihazı
- Equotip-2 brinnell - rockwell sertlik ölçüm cihazı
- SONOHARD SH-5A ultrasonik sertlik cihazı (brinnell-rockwell)
- TIME TUD 210 ultrasonik çatlak kontrol test cihazı
- Manyetik partikül çatlak kontrol test cihazı
- Q NET ultrasonik sertlik derinliği ölçüm cihazı
- MAHR milimar C1208 radyal özkatılık ölçüm cihazı
- TIME TV-300 portatif vibrasyon ölçüm cihazı

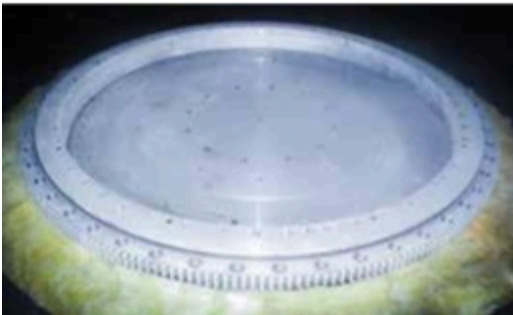

## TEST EQUIPMENTS

- Friction torque test equipment (0-25 °C)
- High temperature test (+55° C)
- Low temperature test (-32° C)
- Relative humidity test device (temperature and humidity controller)
- Rain test
- Airtightness test
- Watertightness test
- Bending test
- Axial load test
- Radial load test
- Water test
- Axial and radial load test
- Radial stiffness test
- Clearance test





## DIEMENSION MEASUREMENT and CONTROL TEST

- *DEA delta slant performance gantry coordinate measuring machine 3000x5200*
- *Romer portative 3D measurement device*
- *METKON bacalite moulding device*
- *METKON emery and polishing device*
- *METKON disc cutter device*
- *TIME TR 200 roughness measurement device*
- *TIME TT 260 coating thickness measurement device*
- *HM-112 micro vickers hardness measurement device*
- *Equotip - 3 brinnell - rockwell hardness measurement device*
- *Equotip - 2 brinnell - rockwell hardness measurement device*
- *SONOHARD SH-5A ultrasonic hardness measurement device (brinnell - rockwell)*
- *TIME TUD 210 ultrasonic cracked controller device*
- *Magnetic particle cracked test device*
- *Q NET ultrasonic hardness depth measurement device*
- *MAHR milimar C1208 radial stiffness measurement device*
- *TIME TV-300 portative vibration measurement device*





# DEA DELTA SLANT PERFORMANCE ÜÇ BOYUTLU KOORDİNAT ÖLÇME CİHAZI

Cihaz Markası: DEA  
Model: 30.51.20

Cihaz; 3 eksenli CNC kontrollü kızaklı köprü (gantry) teknolojisine sahip koordinat ölçme makinasıdır.

Cihaz eksenleri:  
-X eksen en az 3000 mm,  
-Y eksen en az 5100 mm,  
-Z eksen en az 2000 mm olacaktır.



## DEA DELTA SLANT PERFORMANCE GANTRY COORDINATE MEASURING MACHINE

Device: DEA  
Model: 30.51.20

*This device has 3D Cnc controlled gantry tech to measure.*

Device Axisses:  
-X axis min 3000 mm,  
-Y axis min 5100 mm,  
-Z axis min 2000 mm.



*Başarının olduğu her yerde...*  
*In all places where success comes...*

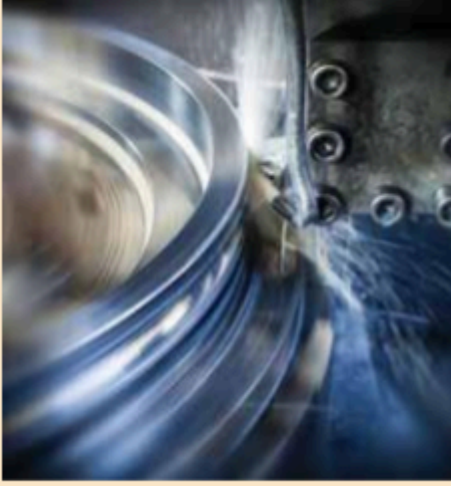

## ■ DÖNER TABLA DİŞLİLERİ VE RULMANLARI

Standart döner tabla dişlileri; mobil vinçler, kule vinçleri, katlanır bomlu vinçler, ekskavatörler, beton santralleri, beton pompaları, robotlar, radarlar, silah sanayii, açık deniz platformları, şişeleme ve dolum tesisleri, özel tasarımı endüstriyel makinalarda, diğer bir deyişle dönme işinin olduğu her yerde kullanılmak üzere özel olarak dizayn edilmektedir. TIBET MAKİNA standart üretimlerinin yanı sıra, talepler doğrultusunda gerçekleştirdiği özel imalatlarıyla da hizmet vermektedir. Kullanılan malzemeler TIBET MAKİNA için özel olarak üretilmektedir. Malzemeler, kullanım alanlarına göre değişik kimyasal özelliklerle imal edilir. Bunlar genel olarak C45, 46Cr2, 46Cr4, 42CrMo4 gibi malzemelerdir. Özel kullanım alanları için demir olmayan metaller, titanyum alaşımli metaller, alüminyum alaşımli metaller ve antistatic malzemeler de kullanılmaktadır. Tasarımı biten parçalar imalata geçer. Talaşlı imalat sonrası parçalar ısıtılma tabii tutulur. Rulman yolları 55-60 Hrc sertleştirilir. Dişler kullanım alanlarına göre sertleştirilir ve/veya meneviş yapılır. Tüm yatakların rulman yolları, hassasiyeti artırmak için taşlanır.

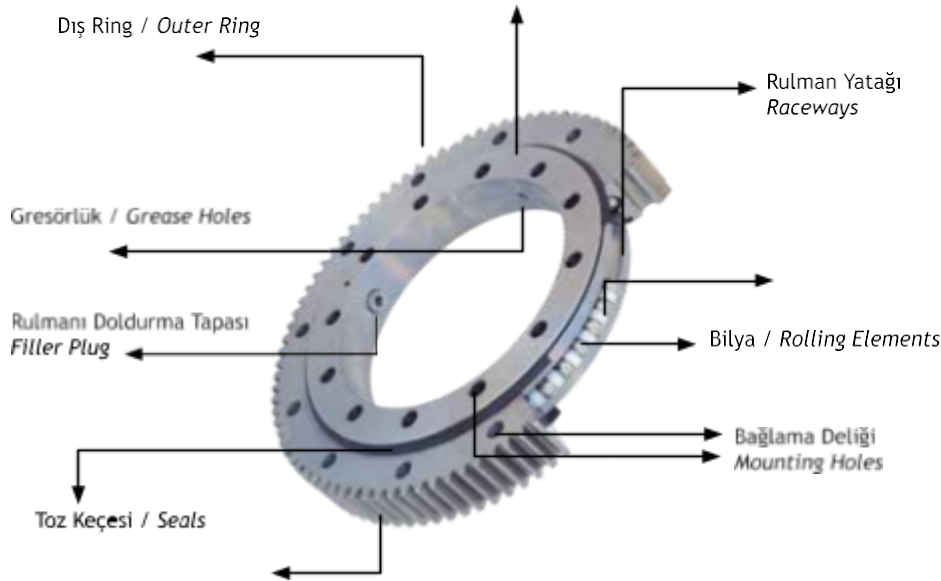

Dişli / Gear

İç Ring / Inner Ring

Ara Parça / Spacers



## A- İmalat Yöntemi / Process of Production



1 Hammadde /  
Raw Material



2 İşleme / Tornalama  
Machining / Turning



3 İndiksiyon /  
Hardening

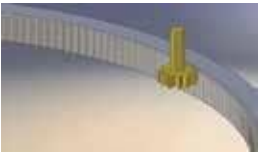

4 Diş Açma  
Gear Cutting

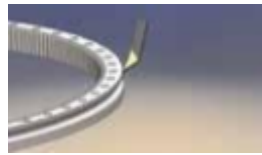
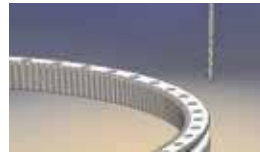

6 Finiş Tornalama /  
Finish Turning

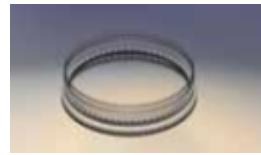

7 Montaj /  
Assembly



8 İçten Dişli Döner Tabla Dişlisi  
Slewing Bearing With Inner Gear

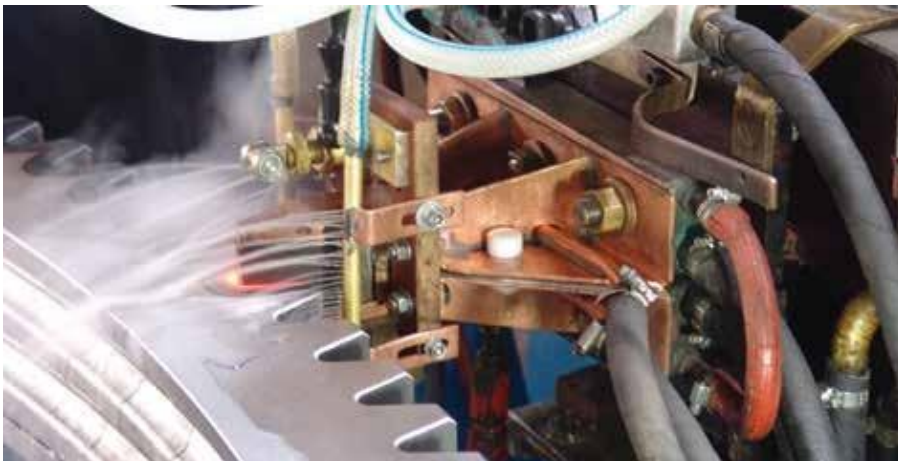

## SLEWING RINGS AND BEARINGS

Standard slewing rings are designed specially for mobile cranes, gantry cranes, tower cranes, knuckle boom cranes, excavators, concrete plants and pumps, robots, index tables, radars, arms industry, open sea platforms, bottling and filling plants, wind turbines; hence, in any field where rotating is involved. In addition to its standard production line, TİBET MAKİNA also serves with some tailor-made production in accordance with consumer orders. The seamless rough rolled ring materials in various compositions according to their fields of application are produced specially for TİBET MAKİNA. These consist of the materials usually like C45, 46Cr2, 46Cr4, 42CrMo4. Non-ferrous metals, titanium alloys, aluminium alloys and antistatic materials are used for special applications. TİBET MAKİNA prefers balls and rollers with very specific characteristics also in the selection of rolling elements. The completion of design leads to the start of the production process. Heat treatment is carried out after the machining process. Raceways are hardened or normalized according to the application. All bearing raceways are ground to decrease the sensitivity and friction after the thermal process.

*İletişimin gücü...*  
*Power of communication...*





## I. Ham Madde

Üretimimizde temel olarak ithal, eksiz vaslenmiş çember kullanılmaktadır.

Avrupa'dan birçok farklı tedarikçiden hammadde ithal eden firmamızın bu konuda geniş bir tedarikçi ağı bulunmaktadır. Standart üretimlerimizde kullanmış olduğumuz ham maddeler; malzeme analizleri raporları ve EN10204 3.1 sertifikaları ile ithal edilmekte olup, kalite standartlarımız gereği izlenebilirlik adına ürün seri numaraları ile eşleştirilerek kayıt altında tutulmaktadır. Özel imalat ürünlerde ise; dişlilerin kullanım alanlarına göre; aşağıdaki (EN10204 3.2) sertifikasyonlardaki ham maddeler kullanılmaktadır.

- Bureau Veritas
- I.S.P.E.S.L.
- Lloyd's Register of Shipping
- T.U.V.
- Det Norske Veritas
- Germanischer Lloyd
- American Bureau of Shipping
- RINA

Kullanım alanlarına göre hafif seri olarak adlandırılan küçük çaplı ürünlerde kıvrıma malzeme de kullanılabilenekte olup, bu malzemenin kıvrıma ve normalizasyon işlemleri kendi tesislerimizde yapılmaktadır.

## I. Raw Materials

Imported seamless rolled rings (forged rings) are primarily used in our production.

Our company imports raw materials from many different suppliers in Europe, has a wide supplier network in this regard.

Raw materials are used in our standard manufacturing, are imported with material analysis reports and EN10204 3.1 Certificates and these are matched with serial numbers and are recorded to correspond traceability in standard of quality.

In special manufacturing as per the usage areas; the raw materials with the following certifications (EN10204 3.2) are also procured.

- Bureau Veritas
- I.S.P.E.S.L.
- Lloyd's Register of Shipping
- T.U.V.
- Det Norske Veritas
- Germanischer Lloyd
- American Bureau of Shipping
- RINA

Bending material may also be used for small diameter products called as light series according to the usage areas, bending and normalization operations of referred material are performed in our own facilities.





## II. Kaplama

TİBET MAKİNA sektörel ihtiyaçlar doğrultusunda üretmiş olduğu dişli ve rulmanlar üzerine çeşitli yüzey kaplamalarını uygulamaktadır. Kaplama prosesindeki temel amaç; ürüne kullanım yeri ve çalışma şartlarına göre yüzey koruması sağlamak, dolayısıyla da dayanımını artırmaktır.

### TİBET MAKİNA'DA YAPILAN KAPLAMA İŞLEMLERİ

#### 1) Sert Eloksal Kaplama:

Tank Ebatları: 4000 x 4000 x 200 mm

Çalışılan Standartlar:

MIL-STD-8625 Tip-III Class- I, Sert Eloksal Kaplama

MIL-STD-8625 Tip II Class- I, Eloksal kaplama

#### 2) Kuşlama:

Standart DIN 8567 ISO 8501-1

#### 3) Sıcak Çinko Püskürtme İle Kaplama:

Tesis Ebatları: Ø3200 mm kadar ring malzemelerine kaplama yapılır.

Çalışılan Standartlar: EN 22063

#### 4) Mangan Fosfat Kaplama:

Tank Ebatları: 2300 x 1200 x 550 mm

Çalışılan Standartlar: TS EN 12476

#### 5) Çinko Bikromat Kaplama:

Çalışılan Standartlar: TS EN 2081 metalik ve diğer inorganik kaplamalar. Demir veya çelik üzerinde ek tedaviler ile çinko elektrolitik kaplama

#### 6) Kimyasal Pasivasyon:

Çalışılan Standartlar: ASTM A967 - 05E2 Paslanmaz çelikler için kimyasal pasivasyon

#### 7) Alüminyum Dişli Yüzeyine Kromat Kaplama:

Çalışılan Standartlar: MIL-STD-C-5541, Sınıf 1 A standardına uygun alüminyum dişli yüzeyine kromat kaplama

#### 8) Sert Krom Kaplama:

Çalışılan Standartlar: Sert krom korozyon direnci kontrolü TS EN 10289

**ASKERİ STANDART:** MIL-P-8585 (TT-P1757) Zinc chromate primer  
MIL-C-8514  
MIL-C-83286



## II. Coating

TIBET MAKINA has ability to *apply* different kinds of coating on slewing rings and bearings according to industrial needs. Main Purpose of coating is increasing resistance of the surface against environmental conditions so increasing strength.

### COATING TYPES AT TIBET MAKINA

#### 1) Hard Anodizing Coating

Reservoir Sizes: 4000 x 4000 x 200 mm

According to;

MIL-STD-8625 Tip-III Class- I, Hard Anodizing Coating Standart

MIL-STD-8625 Tip II Class- I, Anodizing Coating Standart

#### 2) Sand Blasting:

According to; DIN 8567 with ISO 8501-1 Standart

#### 3) Zinc Spray Coating:

Reservoir Sizes: Rings up to  $\varnothing 3200$  mm dia

According to; EN 22063 Standart

#### 4) Manganese Phosphatizing:

Reservoir Sizes: 2300 x 1200 x 550 mm

According to; TS EN 12476 Standart

#### 5) Zinc Dichromate Coating:

According to; TS EN 2081 Standart Metallic and other inorganic coatings. Repairment on ferrous and stainless material with zinc electrolitic coating

#### 6) Chemical Passivating:

According to; ASTM A967-05E2 Chemical Passivating for stainless steel

#### 7) Chromate Coating on Aluminum Gear Surface:

According to; MIL-STD-C-5541, Class1 A standart

#### 8) Hard Chrome Coating:

According to; Hard chromium corrosion resistance control

TS EN 10289

Military Standarts: MIL-P-8585 (TT-P1757) Zinc chromate primer

MIL-C-8514

MIL-C-83286



### III. Montaj

Yatağın makineye bağlandığı yüzeyler düzgün ve işlenmiş olmalıdır. Kaynak gerilmeleri, boya kalıntıları, çapak vs. gibi yatağın dönmesini engelleyecek etkenler mutlaka giderilmelidir. Montaj öncesi oturma yüzeyleri kesinlikle kontrol edilmelidir.

Bununla ilgili oturma yüzey toleransları Tablo 1'de gösterilmiştir.

Montajda kesinlikle dolgu malzemesi, şim vs. ürünler kullanılmamalıdır. Yatak yüzeye bağlandıktan sonra, birkaç tur döndürülmeli ve bir sıkma olup olmadığı kontrol edilmelidir.

Montaj sırasında DIN 267'ye uygun 10.9 cıvata kullanılmalı ve Tablo 2'deki toleranslarda sıkılmalıdır. Sıkma işlemi Şekil 1'de görüldüğü şekilde yapılmalıdır.



Şekil 1 / Figure 1

OTURMA YÜZEY TOLERANSLARI / SURFACE FLATNESS TOLERANCES			
Rulman Eksen Çapı Track Diameter (mm)	Tek Sıra Küresel Bilyalı Yataklar Single Row Ball Bearing	Çift Sıra Küresel Bilyalı Yataklar Double Row Ball Bearing	Masuralı Yataklar Roller Bearing
0-500	0.10	0.15	0.07
500-1000	0.15	0.20	0.10
1000-1500	0.19	0.25	0.12
1500-2000	0.22	0.30	0.15
2000-2500	0.25	0.35	0.17
2500-4000	0.30	0.40	0.20

Tablo 1 / Table 1

CIVATALAR İÇİN TORK DEĞERLERİ / TORQUE VALUES FOR BOLTS						
Anma Çapı	8.8		10.9		12.9	
Diameter (Metric)	Tork (Nm)	FM (N)	Tork (Nm)	FM (N)	Tork (Nm)	FM (N)
M6X1	10.00	9000	14.00	13200	16.00	15400
M8X1,25	23.00	16500	34.00	24200	40.00	28500
M10X1,5	45.00	26000	67.00	38500	77.00	45000
M12X1,75	80.00	38500	115.00	56000	135.00	66000
M14X2	125.00	53000	185.00	77000	215.00	90000
M16X2	195.00	72000	285.00	106000	335.00	124000
M18X2,5	280.00	91000	395.00	129000	465.00	151000
M20X2,5	395.00	117000	560.00	166000	655.00	194000
M22X2,5	540.00	146000	770.00	208000	900.00	243000
M24X3	680.00	168000	970.00	239000	1130.00	280000
M27X3	1000.00	221000	1420.00	315000	1670.00	370000
M30X3,5	1360.00	270000	1930.00	385000	2260.00	450000
M33X3,5	1850.00	335000	2630.00	480000	3080.00	560000
M36X4	2380.00	395000	3380.00	560000	3960.00	660000

Tablo 2 / Table 2

### III. Mounting

The surfaces, where the bearing is assembled to the machine, should definitely be smooth and processed. The factors that will prevent the bearing from rotating, such as welding tensions, dye accumulations or burr etc. has to be removed definitely. The surface flatness should definitely be checked before the assembly.

The Surface Flatness tolerances in relation therewith are indicated in Table 1.

The products such as filling materials, shims etc. should definitely not be used in the mounting. After the bearing is assembled to the surface, it should be rotated a few tours and it should be checked whether there is any clamping.

During the assembly, 10.9 bolt in compliance with DIN 267 should be used and it should be screwed at the tolerances as indicated in Table 2. The screwing operation should be performed as indicated in Figure 1.



#### IV. Sertlik Aralığı

Sertlik aralığı, rulman yatağındaki sertleşmenin başladığı ve bittiği yer arasında kalan bölgedir. (S) harfi ile tanımlanır ve markalanır. Markalama işlemi, montaj sırasında yatağın oturma yüzeyi dışında kolay görülecek yerlere veya tapa yerine yapılır. Montaj sırasında bu bölge, ana yük taşıma alanları dışında kalmalıdır.

#### IV. Hardness Range

*The hardness range is an area between the place where the hardening in the bearing race starts and the place where the hardening in the bearing race ends. It is identified and marked with the letter (S). The marking is made during the assembly to the places to be easily seen outside the surface flatness of the bearing or to the plug place. During the assembly, the referred area should stay outside the main load bearing areas.*

Şekil 2 / Figure 2

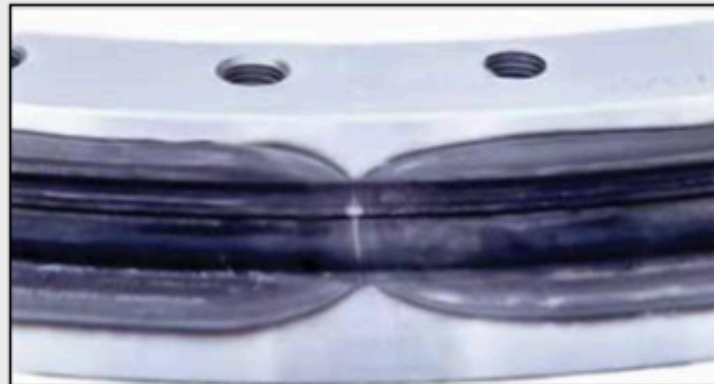

## V. Pinyon

Geometrik yönden doğru profillere ve teorik olarak yeterli dişlilere rağmen yüksek stres altındaki dişlilerde kavrama sorunlarıyla karşılaşmak mümkündür. Şekil 3'te gösterildiği gibi çark dişi yan yüzeyinde "aşınma" ya da "çentme" meydana gelebilir. Bu durum özellikle, pinyon uç kenarlarının kazıyıcı görevi gördüğü sertleştirilmiş pinyonlarda oluşur. Çeşitli sebepler söz konusu olabilir.

Çoğu döner tahrik ünite üstten sarkacak şekilde bir düzlemde monte edilir ve böylelikle pinyon milindeki sapmaların önüne geçmek mümkün olmaz. Bu durum, yüksek kuvvetlerde aynı zamanda pinyon mili ile yatak oturma yüzeyi arasında elastik deformasyonlara da yol açar. Bu türden deformasyonlar kavrama sorunlarını da beraberinde getirebilir.

Belirtilen bu üç önemli faktör pinyon uç kenarına etki eden yüksek yüklere yol açar ve yağlayıcı tabakasında yırtılmaya sebep olabilir.

Doğrudan metal teması çentilme etkisini artıracaktır.

Geçmişte ara sıra meydana gelmiş olan hasarlar, pinyon ucunda ve pinyon uç kenarında bir yarı çap temin edilmesiyle önlenebilir. Pinyon ucunun azaltılması yüksek hızlı dişli mekanizmalarındaki vibrasyon (gürültü) etkilerinin düşürülmesi için bir çözüm haline gelmiştir. Yapılan araştırmalar, aşın yük şartları altındaki uygulamalarda aşağıda verilen formüle göre eksiltme yapılmasını öngörür.

Şekil 3 / Figure 3

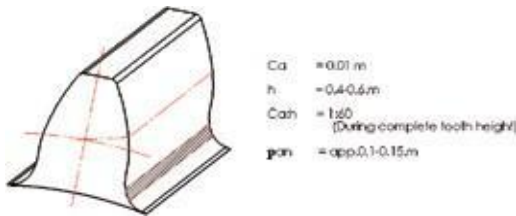

Şekil 4 / Figure 4



Şekil 5 / Figure 5

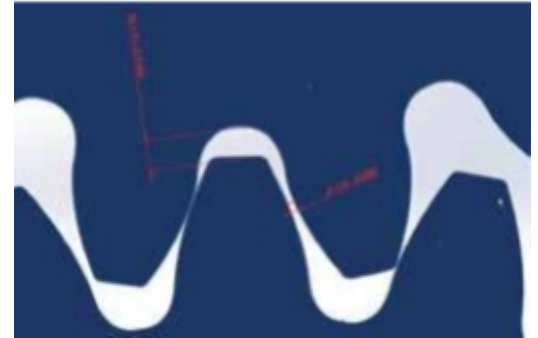

Pinyon ile dişli arasındaki boşluk şekil 5'te gösterildiği gibi hesaplanır.

Yataklar üzerindeki dişlerde mavi boyalı yerlerden ayar yapılması gerekmektedir.

## V. Pinyon

*Despite geometrically proper profiles and theoretically sufficient gears, it is possible to have meshing / clutching problems under high stress. As shown in figure 3 at the flank of gear there is "chipping" or "scuffing". This situation occurs especially in gears with hardened pinions where the pinion tip edges scrape the gear. It may happen due to a various reasons.*

*Most driving units are mounted as suspended from above. Therefore, it is impossible to prevent the deviation at the pinion shaft high forces cause elastic deformation at the interface of the driving unit and mounting structure, which results in meshing problems as well. Also direct contact between two materials increase the chipping effect.*

*Previous damages can be corrected through providing a radius at pinion tip and pinion flanks. Decreasing the pinion tip is usually a solution to reduce the vibration (noise) effects of gear mechanism that operate at high velocity. Some decreases at excessive loading conditions can be done according to following formulas obtained through researches:*

*The space between pinion and gear is calculated according to Figure 5. During the mounting process, gears and pinion should be adjusted from the place where gear painted in blue.*



## VI. Ambalajlama, Depolama ve Nakliye

Standart ambalaj şekli oda sıcaklığında 2 yıla kadar koruma sağlar.

Yatağın dış yüzeyi TECTYL 506 veya OKS 500 koruyucu yağ ile kaplandıktan sonra, yatak özel nem alıcı koruyucu bir kağıt ile sarılarak ambalajlanır. Ürün tahta palet üzerine sabitlenerek sevkiyata hazır hale getirilir.

Taşınacak ürünün özelliğine ve müşterinin talebine göre; özel taşıma aparatları veya özel kasalar da yapılabilmektedir.



## VI. Packaging, Storing and Shipment

The standard packaging type provides protection up to 2 years in room temperature.

After the external surface of the bearing is covered with the protective grease TECTYL 506 or OKS 500, the bearing is packed by being wrapped with a special dehumidifier protective paper. The product is made ready for shipment by means of being fixed on a wooden pallet.

Pursuant to the qualification of the product to be shipped and the demand of the customer, special carriage apparatus or special cases may also be made.

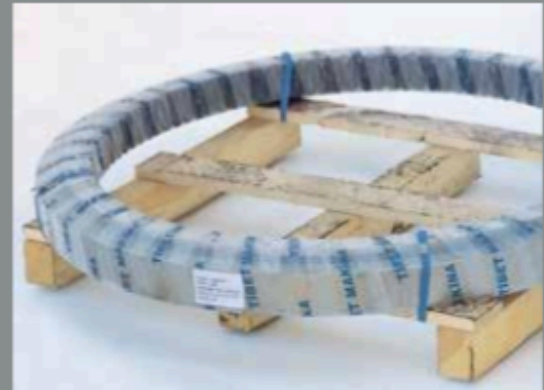



Demirçelik Sektörü  
*Iron and Steel Industry*



Rüzgar Türbinleri  
*Wind Industry*

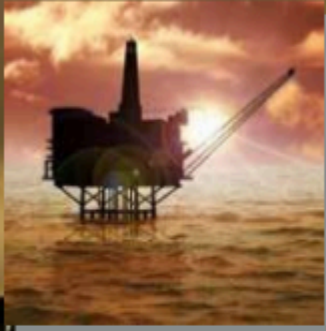

Açık Deniz Platformları  
*Offshore Applications*



Lunapark Makineleri  
*Funfair Machines*

## ■ UYGULAMALAR / APPLICATIONS



İnşaat Sektörü  
*Construction Industry*



Gemi Vinçleri  
*Marine Cranes*



Komünikasyon Sektörü  
*Communication Industry*



Mobil Vinçler  
*Mobile Cranes*

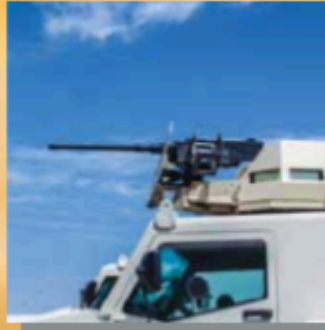

Savunma Sanayii  
*Defence Industry*



İş Makineleri / Ekskavatör Sanayii  
*Heavy Construction Equipments  
and Excavators*



Medikal Uygulamalar  
*Medical Applications*



Liman Vinçleri  
*Gantry Cranes*



Şişeleme ve Dolum Tesisleri  
*Bottling and Filling Facilities*

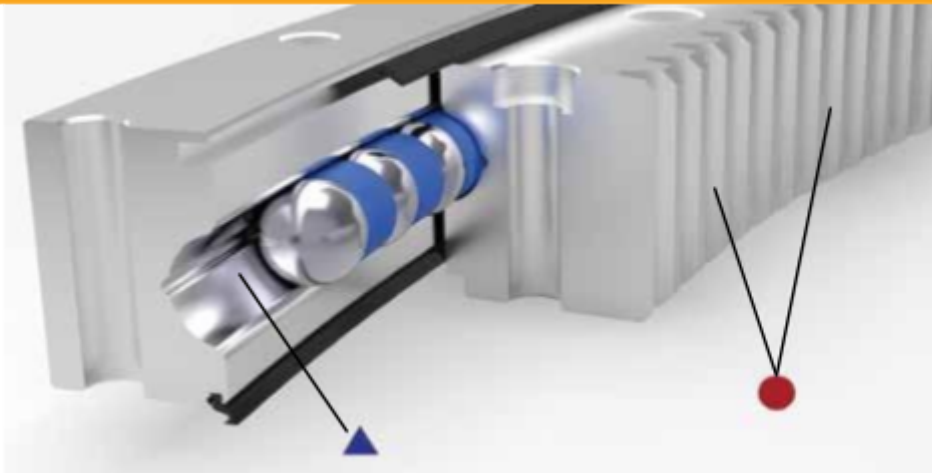

Tablo 3 / Table 3

Aralub  
HLP 2 243 K to 403 K  
(-30° C to + 130° C)

## YAĞLAMA VE BAKIM

Yatağın uzun ömürlü ve sorunsuz olması, yağlamanın ve bakımın iyi olmasıyla sağlanır. Rulman yatakları ilk montaj sırasında yağlanır. Yataklar, makineye veya kullanıldığı yere montajı yapılır yapılmaz hemen yağlanmalıdır. Normal şartlarda Tablo 3'e göre yağlama yapılmalıdır. Rulman yataklarının belirtilen sıcaklık ve şartlar dışında çalışması gerekiyorsa teknik servisimize danışılması gerekmektedir.

İlk çalışma sonrasında yağlama 20 saat sonra, periyodik olarak da her 50 saatte bir tekrarlanmalıdır.

Makine uzun süre çalışmamış ise; çalışma öncesi ve sonrası yağlama yapılmalıdır. Civatalar ilk 100 saat sonunda ve her üç ayda bir sıkılmalıdır. Rulman yataklarına kum, su, vs. gibi aşındırıcı maddelerin kaçmamasına dikkat edilmelidir.



		Aralub MKA-Z1	243 K to 403 K (-30° C to + 130° C)
		Energrease LS-EP 2	253 K to 393 K (-25° C to + 120° C)
		Energrease LC 2	248 K to 433 K (-25° C to + 160° C)
		Spherol EPL 2	248 K to 433 K (-25° C to + 160° C)
		Castrol LZV-EP	243 K to 423 K (-30° C to + 150° C)
		EPEXA 2	243 K to 393 K (-30° C to + 120° C)
		CARDREXA GR 1-AL	243 K to 393 K (-30° C to + 120° C)
		BEACON EP2	248 K to 403 K (-25° C to + 130° C)
		Esso Multi Purpose grease (Maly)	248 K to 403 K (-25° C to + 150° C)
		CENTROPLEX 2 EP	253 K to 403 K (-20° C to + 130° C)
		GRAFLOSCON C-5G 0 Ultra	243 K to 473 K (-30° C to + 200° C)
		Mobilux EP 2	248 K to 393 K (-25° C to + 120° C)
		Mobiltac B1	253 K to 393 K (-20° C to + 120° C)

## LUBRICATION AND MAINTENANCE

In order for the bearing to have a long life without problems, the lubrication and maintenance should be performed well. The bearing races are lubricated during the first assembly. The bearings must be lubricated immediately after they are first assembled to the machine or wherever they are used. Under ordinary conditions, lubrication should be materialized in accordance with the Table 3. If the bearing races are required to operate outside the specified temperature and conditions, it is required to consult our technical service.

Lubrication must be repeated 20 hours after the first operation and thereafter once in every 50 hours periodically.

If the machine has not been operating for long time, lubrication must be done before and after operation. The bolts should be screwed at the end of the first 100 hours and once in every 3 months. Attention should be paid that no abrasive materials such as sand, water etc. enter the bearing races.

		Shell Malleus GL 95	253 K to 423 K (-20° C to + 150° C)
--	--	------------------------	--



## HESAPLAMALAR / CALCULATIONS

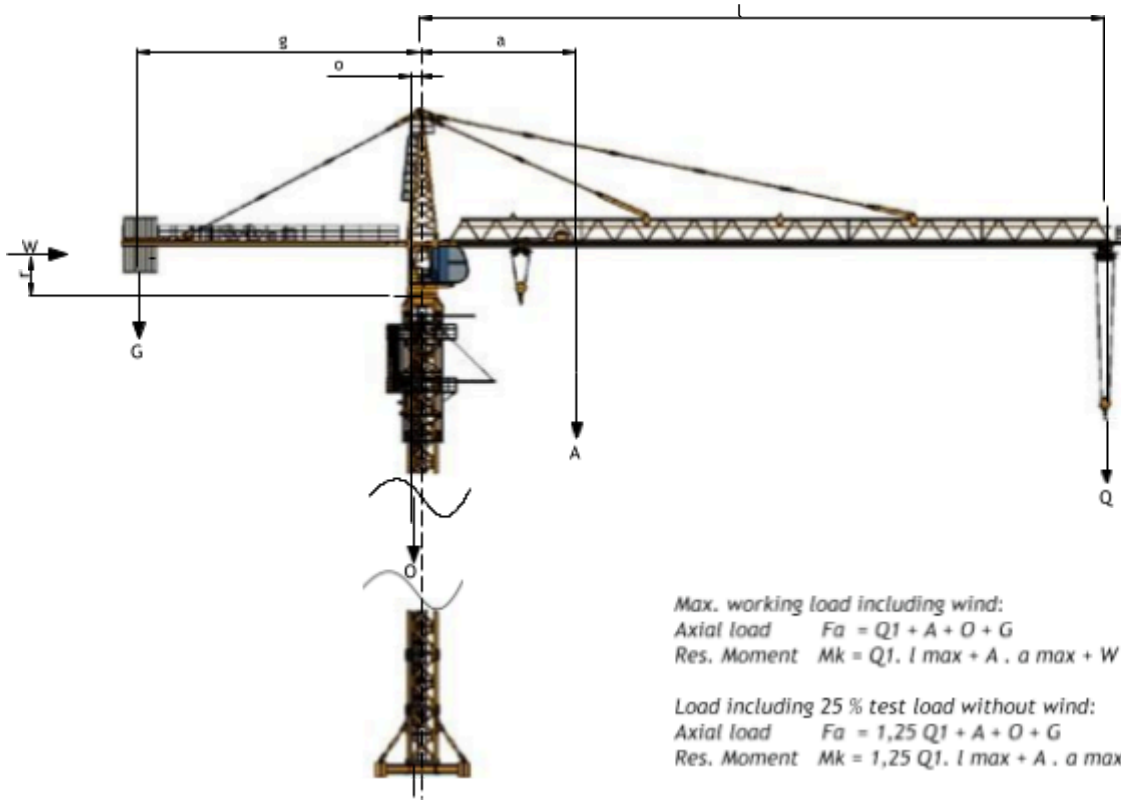

Max. working load including wind:

$$\text{Axial load } Fa = Q1 + A + O + G$$

$$\text{Res. Moment } Mk = Q1 \cdot l \max + A \cdot a \max + W \cdot r - O \cdot o - G \cdot g$$

Load including 25 % test load without wind:

$$\text{Axial load } Fa = 1,25 Q1 + A + O + G$$

$$\text{Res. Moment } Mk = 1,25 Q1 \cdot l \max + A \cdot a \max + W \cdot r - O \cdot o - G \cdot g$$

## KOD BİLGİ SİSTEMİ / DRAWING NUMBER COMPOSITION

1026E-01B-100

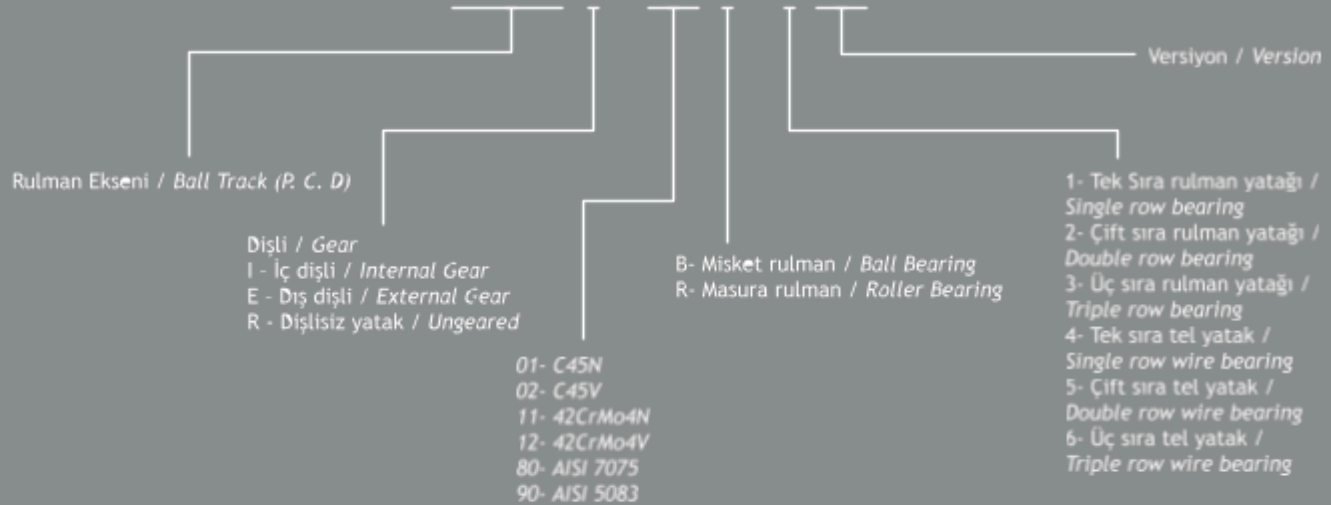

## YATAK SEÇİM BİLGİ FORMU / INFORMATION FORM OF BEARING CHOICE

FİRMA ADI / COMPANY			ADRES / ADDRESS			
YETKİLİ ADI - SOYADI / CONTACT PERSON			DEPARTMAN / DEPARTMANT			
TEL NO			FAX NO			
UYGULAMALAR / APPLICATIONS	VİNÇ / CRANE	EKSKAVATÖR / EXCAVATOR	SAVUNMA SANAYİ / DEFENCE SYSTEM	LUNAPARK / FUN FAIR	DİŞERLERİ / OTHERS	
KULLANIM ALANLARI / USAGE AREAS	KARA / LAND			DENİZ / SEA		
ÇALIŞMA SICAKLIĞI / OPERATING TEMPERATURE						
DİŞLİ TİPİ / TYPE OF GEAR	İÇTEN / INNER		DIŞTAN / EXTERNAL		DİŞLİSİZ / UNGEAR	
RULMAN DİZAYN TİPİ / BEARING DESIGN TYPE	TEK SIRA KÜRESEL BİLYALI / SINGLE ROW BALL BEARING	TEK SIRA SİLİNDİRİK MASURALI / SINGLE ROW ROLLER BEARING	ÇİFT SIRA KÜRESEL BİLYALI / DOUBLE ROW BALL BEARING	ÜÇ SIRA MASURA YATAK / THREE ROW ROLER BEARING	PROFİL YATAKLAR / PROFILE BEARING	DİŞERLERİ / OTHERS
ÖLÇÜLER / DIMENSIONS	Ø MIN.mm	Ø MAX.mm	DİŞ BİLGİLERİ / GEAR DATA			
DIŞ ÇAP / OUTER DIA.			MODÜL / MODULE			
İÇ ÇAP / INNER DIA.			DİŞ SAYISI / NUMBER OF TEETH			
DIŞ RİNG DELİK EKSENİ / EXTERNAL BOLT CIRCLE			DİŞ SULAMA / HARDENED TEETH			
İÇ RİNG DELİK EKSENİ / INTERNAL BOLT CIRCLE						
YÜKLER / LOADS	MAX.ÇALIŞMA / OPERATION		MAX.TEST		DÖNME EKSENİ / ROTATION AXIS	
EKSENEL YÜK / AXIAL LOAD		KN		KN	YATAY / HORIZONTAL	
RADYAL YÜK / RADIAL LOAD		KN		KN	DÜŞEY / VERTICAL	
MOMENT		KNm		KNm	AÇILI / ANGLE	
DEVİR DEĞERLERİ (dev/dak.) / NO OF REV. (Rpm)	NOMINAL / NOM:			MAKSİMUM / MAX.:		
DİŞLİNİN İLETTİĞİ TORK / DRIVE TORQUE AT THE BEARING (KNm)	NOMINAL / NOM:			MAKSİMUM / MAX.:		
KAPLAMA İSTENİYOR MU? / COATING :						
TEKNİK BİLGİLER : (Özel çalışma şartları/muayene ve sertifikasyon gereksinimi / malzeme testleri gibi konular belirtir.) TECHNICAL INFORMATION: (Special working conditions / inspection or certification requirements / material tests etc.)						
Lütfen bu formun tamamını doldurun. Eksik bilgi işleminizi geciktirir. Bireysel danışmaya ihtiyaç varsa, ilgili departmanla irtibata geçiniz. Please fully complete this form. Incomplete information will delay our proposal. If individual required, please call for appointment.						
TARİH / DATE			İMZA / SIGNATURE			



**Tek Sıra Küresel Bilyalı Profil Yataklar (L Tipi)**  
**Single-Row Ball Profile Bearings (Type L)**

**DİŞLİSİZ YATAKLAR / UNGEAR BEARINGS**

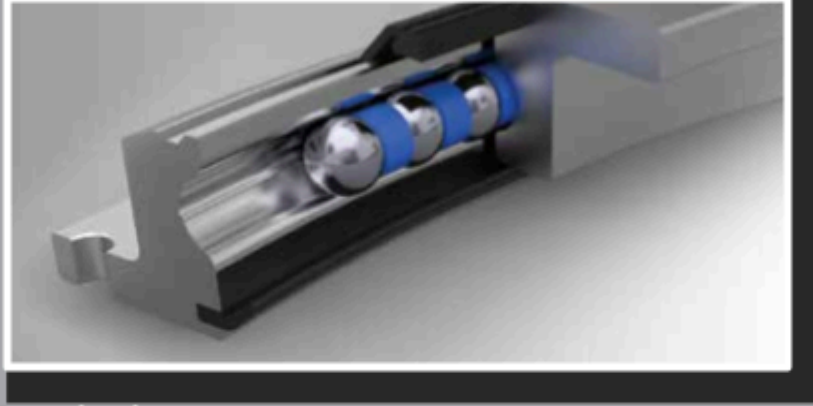

**DİŞTAN DİŞLİ YATAKLAR / EXTERNAL GEAR BEARINGS**

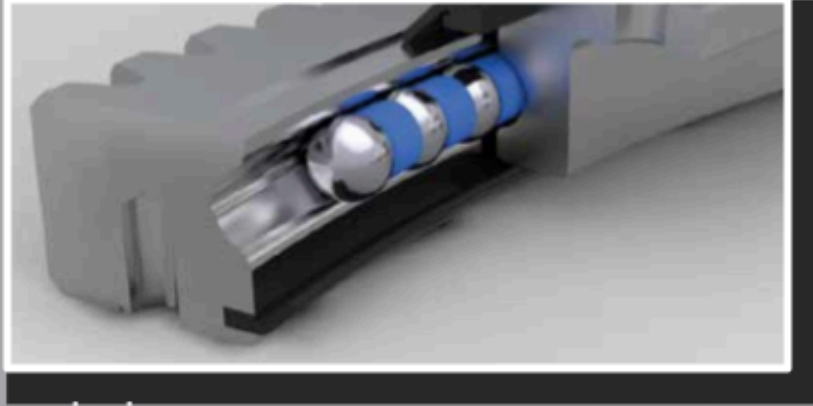

**İÇTEN DİŞLİ YATAKLAR / INTERNAL GEAR BEARINGS**

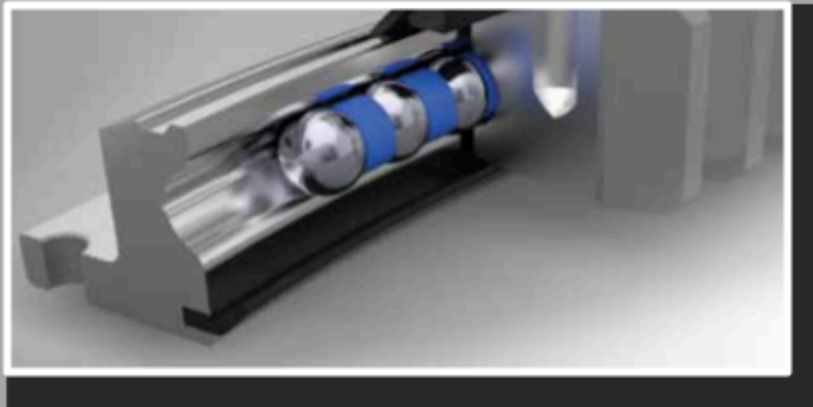

# Tek Sıra Küresel Bilyalı Yataklar (L Tipi) / Single-Row Ball Profile Bearings (Type L)

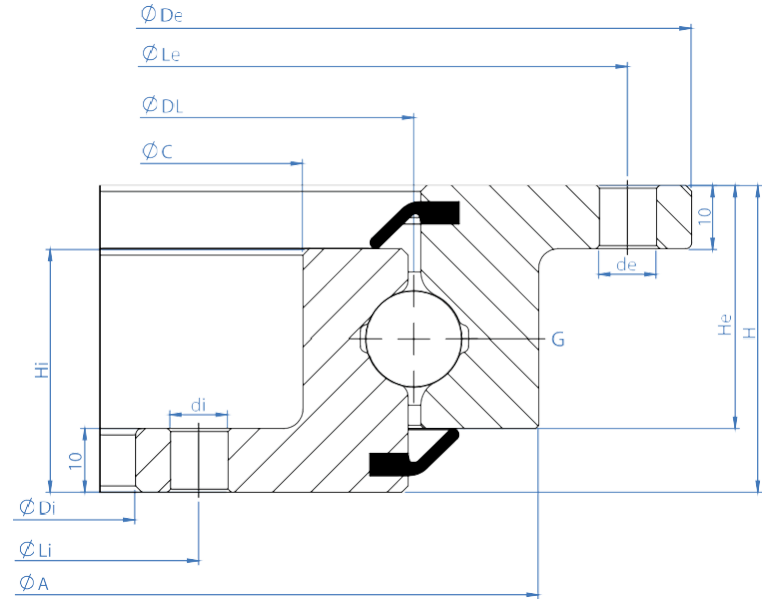
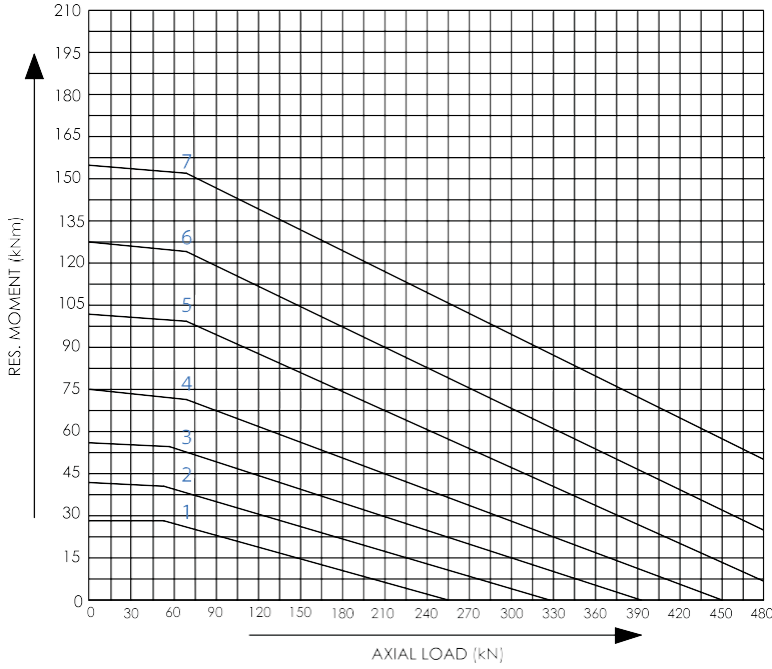

	CODE / KOD	Weight / Ağırlık Kg	Outer Dia. / Dış Çap De	Inner Dia. / İç Çap Di	Ball Track / Dönme Eksenini DL	Diameter / Çap A	Diameter / Çap C	O verä II Height / Toplam Yükseklik H	Outer Ring Height / Dış Ring Yükseklik He	Inner Ring Height / İç Ring Yükseklik Hi	Number Of Grease / Gresörlük Sayısı G	External Bolt Circle Dia./Dış Ring Delik Eksenini La	Internal Bolt Circle Dia./İç Ring Delik Eksenini Li	Number Of Bolt Holes (External) Dış Ring Delik Adedi ne	ni	External Bolt Hole Dia./Dış Ring Delik Çapı de	Internal Bolt Hole Dia./İç Ring Delik Çapı di	Module / Modül m	Number Of teeth / Dış Sayısı z	Addendum Modification / Profil Kaydırma xm	Permissible tangential forces, normal / Müsaade edilen teğetsel kuvvet normal KN	Permissible tangential forces, maximum / Müsaade edilen teğetsel kuvvet , maksimum KN
NO																						
1	0444R-12B-100	26	550	334	444	483	405	56	46	46	4	520	362	16	20	18	18					
2	0544R-12B-102	32	650	434	544	583	505	56	46	46	4	620	462	16	20	18	18					
3	0644R-12B-102	37	750	534	644	683	605	56	46	46	4	720	562	16	20	18	18					
4	0744R-12B-101	44	850	634	744	783	705	56	46	46	4	820	662	16	20	18	18					
5	0844R-12B-103	50	950	734	844	883	805	56	46	46	4	920	762	16	20	18	18					
6	0944R-01B-100	56	1048	834	944	983	905	56	46	46	4	1020	862	16	20	18	18					
7	1044R-12B-100	62	1150	934	1044	1083	1005	56	46	46	4	1120	962	16	20	18	18					

# Tek Sıra Küresel Bilyalı Yataklar (L Tipi) / Single-Row Ball Profile Bearings (Type L)

DIŞTAN DIŞLI / EXTERNAL GEAR

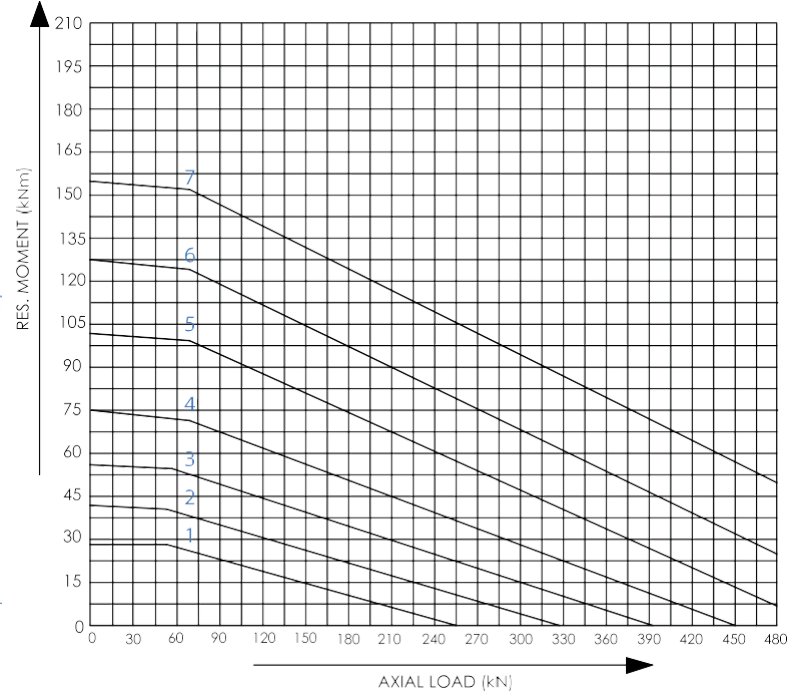
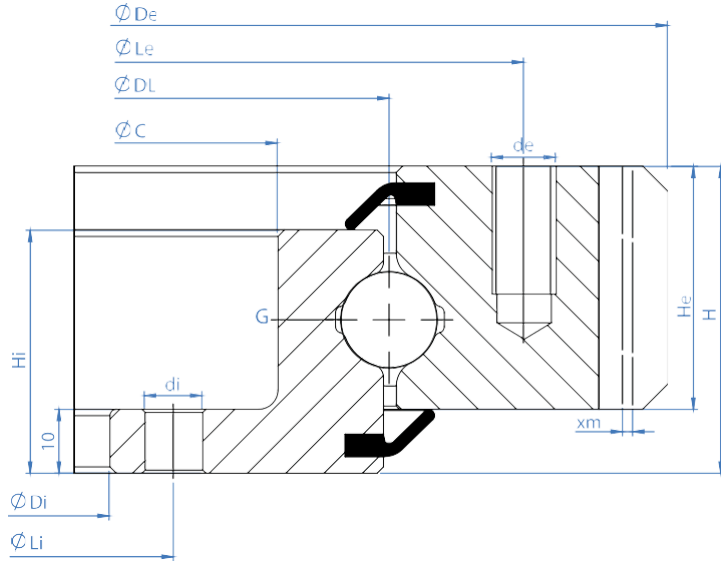

NO	CODE / KOD	Weight / Ağırlık Kg	Outer Dia. / Dış Çap De	Inner Dia. / İç Çap Di	Ball Track / Dönme Eksenli DL	Diameter / Çap C	Overall Height / Toplam Yükseklik H	Outer Ring Height / Dış Ring Yükseklik He	Inner Ring Height / İç Ring Yükseklik Hi	Number Of Grease / Gresörük Sayısı G	External Bolt Circle Dia./Dış Ring Delik Eksenli La	Internal Bolt Circle Dia./İç Ring Delik Eksenli Li	ne	ni	External Bolt Hole Dia./Dış Ring Delik Çapı de	Internal Bolt Hole Dia./İç Ring Delik Çapı di	Module / Modül m	Number Of teeth / Dış Ring Delik Adedi z	Addendum Modification / Profil Kaydırma xm	Permissible tangential forces, normal / Müsaade edilen teğetsel kuvvet normal KN	Permissible tangential forces, maximum / Müsaade edilen teğetsel kuvvet, maksimum KN
1	0444E-12B-100	30	540	334	444	405	56	46	46	4	490	362	10	24	M12	18	5	106		12	24
2	0544E-12B-102	40	642	434	544	505	56	46	46	4	590	462	14	28	M12	18	6	105		14	28
3	0644E-12B-102	48	744	534	644	605	56	46	46	4	690	562	16	32	M12	18	6	122		14	28
4	0744E-12B-103	53	840	634	744	705	56	46	46	4	790	662	18	32	M12	18	6	138		14	28
5	0844E-12B-103	68	952	734	844	805	56	46	46	4	890	762	18	36	M12	18	8	117		19	38
6	0944E-12B-107	74	1048	834	944	905	56	46	46	4	990	862	20	40	M12	18	8	129		19	38
7	1044E-12B-100	86	1152	934	1044	1005	56	46	46	4	1090	962	22	40	M12	18	8	142		19	38



# Tek Sıra Küresel Bilyalı Yataklar (L Tipi) / Single-Row Ball Profile Bearings (Type L)

## İÇTEN DİŞLİ / INTERNAL GEAR

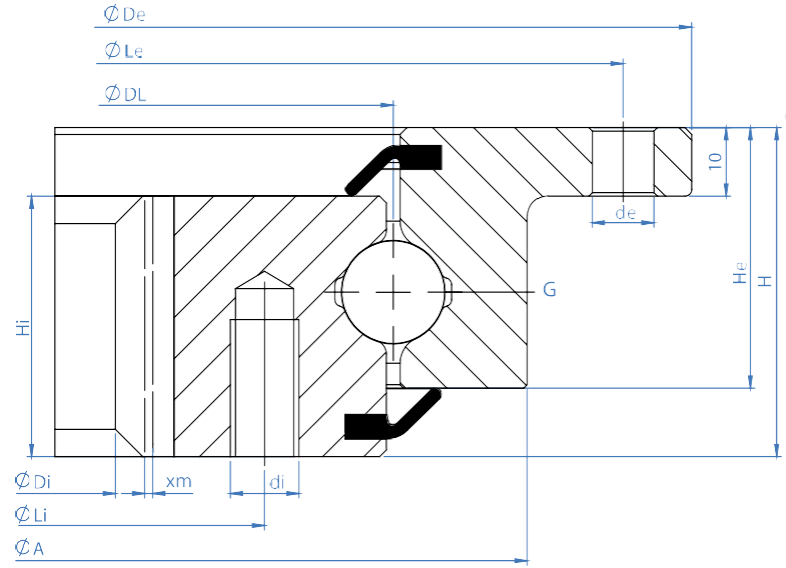
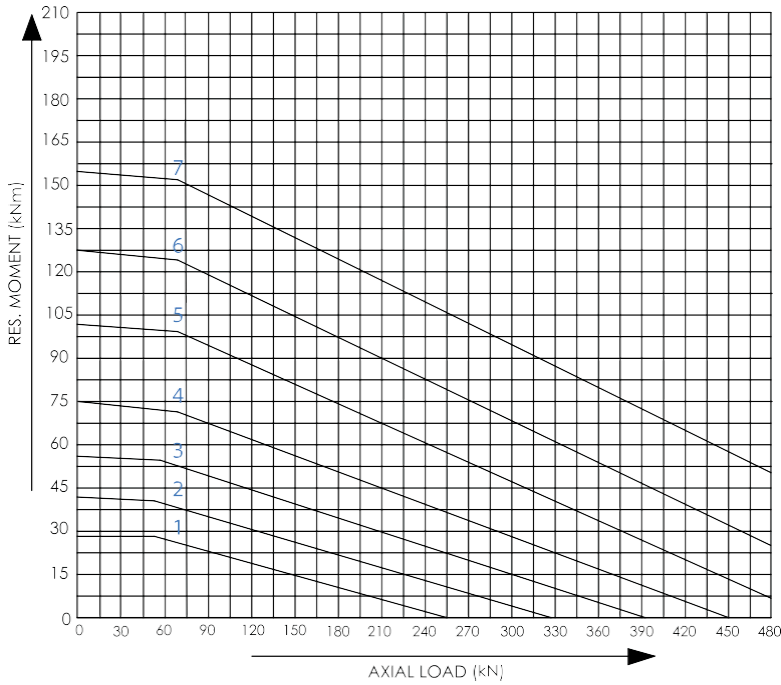

NO	CODE / KOD	Weight / Ağırlık Kg	Outer Dia. / Dış Çap De	Inner Dia. / İç Çap Di	Ball Track / Dönme Eksen DL	Diameter / Çap A	Overall Height / Toplam Yükseklik H	Outer Ring Height / Dış Ring Yükseklik He	Inner Ring Height / İç Ring Yükseklik Hi	Number Of Grease / Gresörtük Sayısı G	External Bolt Circle Dia. / Dış Ring Delik Eksen La	Internal Bolt Circle Dia. / İç Ring Delik Eksen Li	ne	ni	de	di	m	z	xm	Permissible tangential forces, normal / Müsaade edilen teğetsel kuvvet norma I KN	Permissible tangential forces, maximum / Müsaade edilen teğetsel kuvvet, maksimum KN
1	0444I-12B-100	35	550	340	444	483	56	46	46	4	520	395	16	12	18	M12	5	70		14	28
2	0544I-12B-102	43	650	444	544	583	56	46	46	4	620	495	20	16	18	M12	6	76		16	32
3	0644I-12B-103	51	750	540	644	683	56	46	46	4	720	595	24	18	18	M12	6	92		16	32
4	0744I-12B-101	58	850	648	744	783	56	46	46	4	820	700	24	20	18	M12	6	110		16	32
5	0844I-12B-101	71	950	736	844	883	56	46	46	4	920	795	28	20	18	M12	8	94		20	40
6	0944I-12B-100	82	1050	832	944	983	56	46	46	4	1020	895	32	22	18	M12	8	106		20	40
7	1044I-12B-100	89	1150	936	1044	1083	56	46	46	4	1120	1000	32	24	18	M12	8	119		20	40



**Tek Sıra Küresel Bilyalı Yataklar (4 Noktalı Yataklar)**  
**Single-Row Ball Bearings (Four Points Contact Bearings)**

**DİŞLİSİZ YATAKLAR / UNGEAR BEARINGS**

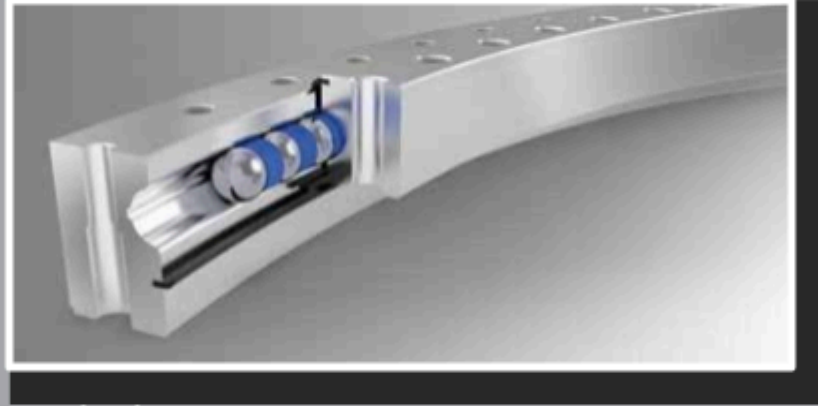

**DİŞTAN DİŞLİ YATAKLAR / EXTERNAL GEAR BEARINGS**

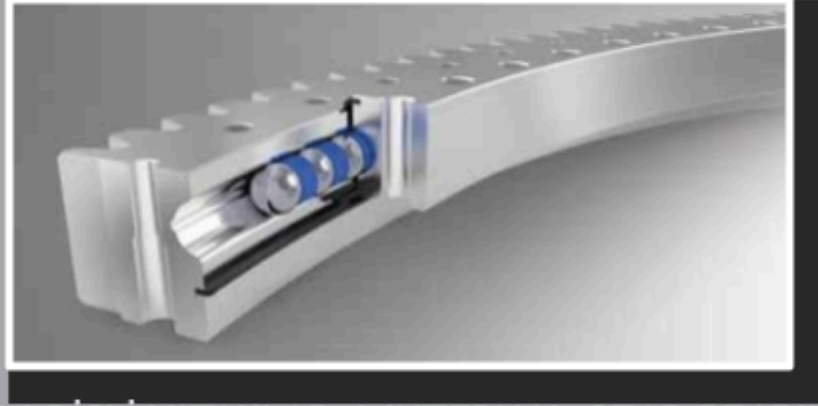

**İÇTEN DİŞLİ YATAKLAR / INTERNAL GEAR BEARINGS**

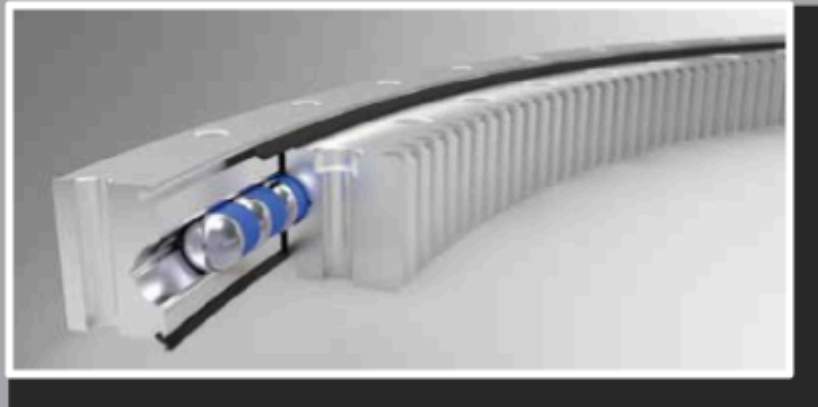

# Tek Sıra Küresel Bilyalı Yataklar (4 Noktalı Yataklar)

## Single-Row Ball Bearings (Four Points Contact Bearings)

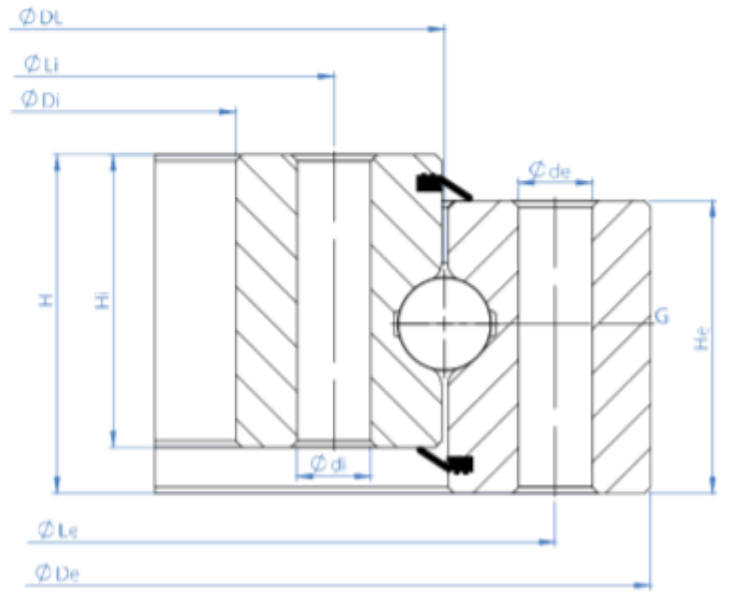
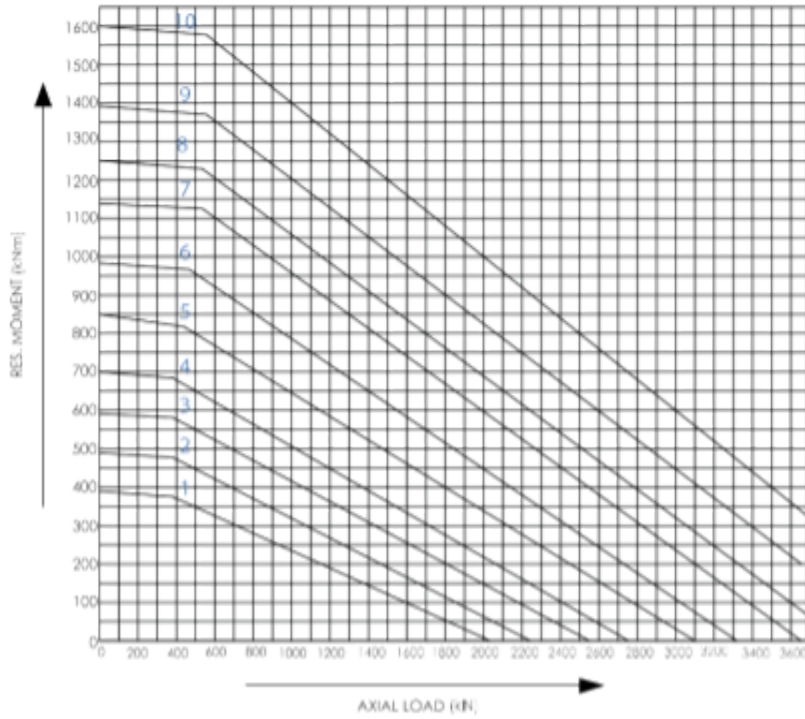

NO	CODE / KOD	Weight / Ağırlık	Outer Dia. / Dış Çap	Inner Dia. / İç Çap	Ball Track / Dönme Eksenli	Overall Height / Toplam Yükseklik	Outer Ring Height / Dış Ring Yükseklik	Inner Ring Height / İç Ring Yükseklik	Number Of Grease / Gresörütük Sayısı	External Bolt Circle Dia. / Dış Ring Delik Eksenli	Internal Bolt Circle Dia. / İç Ring Delik Eksenli	Number Of Bolt Holes (External) / Dış Ring Delik Adedi	Number Of Bolt Holes (Internal) / İç Ring Delik Adedi	External Bolt Hole Dia. / Dış Ring Delik Çapı	Internal Bolt Hole Dia. / İç Ring Delik Çapı	Module / Modül	Number Of teeth / Diş Sayısı	Addendum Modification / Profil Kaydırma
		w	D <sub>e</sub>	D <sub>i</sub>	DL	H	Hi	Hi	G	Le	Li	ne	ni	de	di	m	z	xm
1	0950R-12B-100	130	955	745	850	80	70	70	4	915	730	28	28	22	22			
2	0950R-12B-100	145	1055	845	950	80	70	70	4	1015	890	30	30	22	22			
3	1050R-12B-100	160	1155	945	1050	80	70	70	4	1115	990	30	30	22	22			
4	1150R-12B-100	175	1255	1045	1150	80	70	70	4	1215	1090	36	36	22	22			
5	1250R-12B-100	190	1355	1145	1250	80	70	70	6	1315	1190	36	36	22	22			
6	1350R-12B-100	205	1455	1245	1350	80	70	70	6	1415	1290	42	42	22	22			
7	1450R-12B-100	220	1555	1345	1450	80	70	70	6	1515	1390	42	42	22	22			
8	1550R-12B-100	235	1655	1445	1550	80	70	70	6	1615	1490	42	42	22	22			
9	1650R-12B-100	250	1755	1545	1650	80	70	70	6	1715	1590	42	42	22	22			
10	1750R-12B-100	265	1855	1645	1750	80	70	70	6	1815	1690	42	42	22	22			

# Tek Sıra Küresel Bilyalı Yataklar (4 Noktalı Yataklar)

## Single-Row Ball Bearings (Four Points Contact Bearings)

DIŞTAN DIŞLI / EXTERNAL GEAR

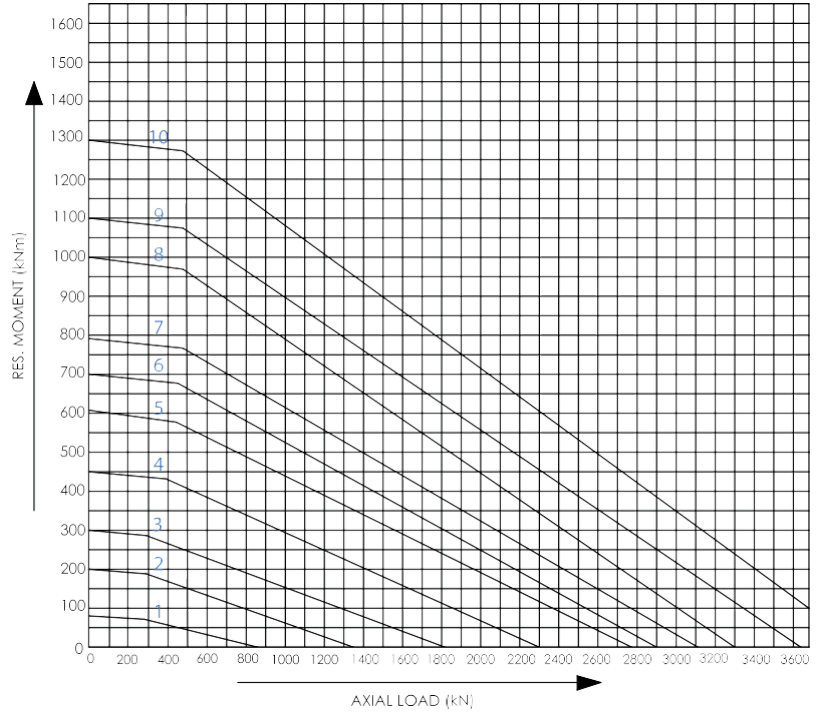
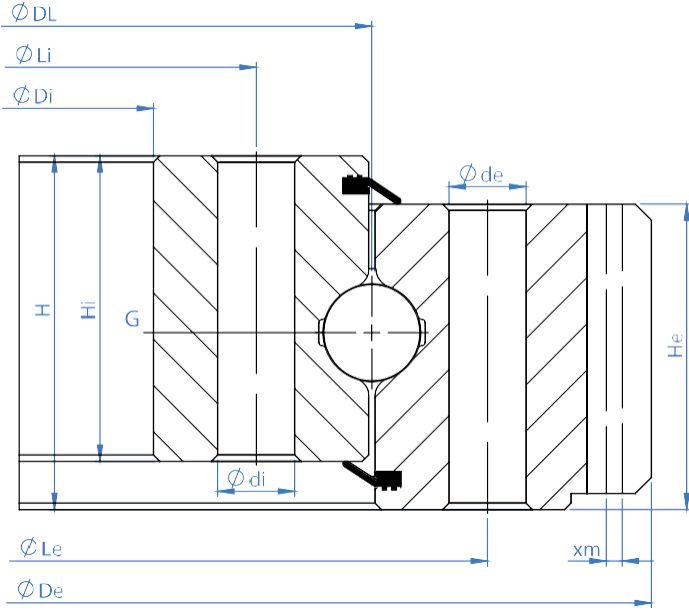

NO	COD KOD	Di	DL	H	Hi	G	La	Li	ne	ni	m	z	xm	KN	KN				
1	0498E-01B-100	65	600	397	498	65	55	55	2	544	453	18	18	17	17	5	118	20	40
2	0692E-01B-100	90	800	612	692	70	60	60	3	745	644	24	24	17	17	5	158	22	44
3	0750E-01B-100	180	900	632	750	93	80	80	3	815	684	24	24	22	22	10	88	60	120
4	0872E-01B-100	280	1050	750	872	110	95	95	4	950	800	24	24	24	24	10	103	72	144
5	1026E-01B-100	305	1200	910	1026	110	95	95	4	1098	954	36	36	24	24	10	118	72	144
6	1155E-12B-101	220	1300	1055	1155	80	70	70	4	1216	1095	42	42	22	22	10	128	52	104
7	1256E-12B-100	240	1400	1155	1256	80	70	70	6	1316	1195	42	42	22	22	10	138	52	104
8	1355E-12B-101	260	1500	1255	1355	80	70	70	6	1416	1295	42	42	22	22	10	148	52	104
9	1455E-12B-101	275	1600	1355	1455	80	70	70	6	1516	1395	48	48	22	22	10	158	52	104
10	1555E-12B-100	290	1700	1455	1555	80	70	70	6	1616	1495	48	48	22	22	10	168	52	104

di: Internal Bolt Hole Dia./İç Ring Delik Çapı

z: Number of teeth / Diş Sayısı

xm: Addendum Modification / Profil Kaydırma

KN: Permissible tangential forces, maximum / Müsaade edilen teğetsel kuvvet, maksimum

KN: Permissible axial forces, maximum / Müsaade edilen aksiyel kuvvet, maksimum

DL: Outer Dia. / Diş Çapı

DL: Internal Bolt Circle Dia. / Diş Ring Delik Ekseni

Li: Internal Bolt Circle Dia. / İç Ring Delik Ekseni

Li: Outer Ring Height / Diş Ring Yükseklik

ne: Outer Ring Height / Diş Ring Yükseklik

ni: Outer Ring Height / Diş Ring Yükseklik

m: Module / Modül

z: Number of teeth / Diş Sayısı

xm: Addendum Modification / Profil Kaydırma

KN: Permissible tangential forces, maximum / Müsaade edilen teğetsel kuvvet, maksimum

KN: Permissible axial forces, maximum / Müsaade edilen aksiyel kuvvet, maksimum

DL: Outer Dia. / Diş Çapı

DL: Internal Bolt Circle Dia. / Diş Ring Delik Ekseni



# Tek Sıra Küresel Bilyalı Yataklar (4 Noktalı Yataklar)

## Single-Row Ball Bearings (Four Points Contact Bearings)

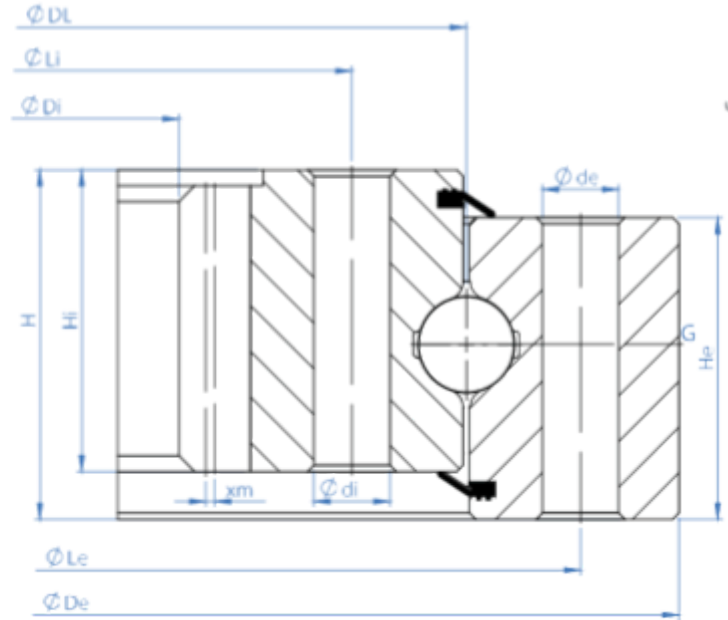
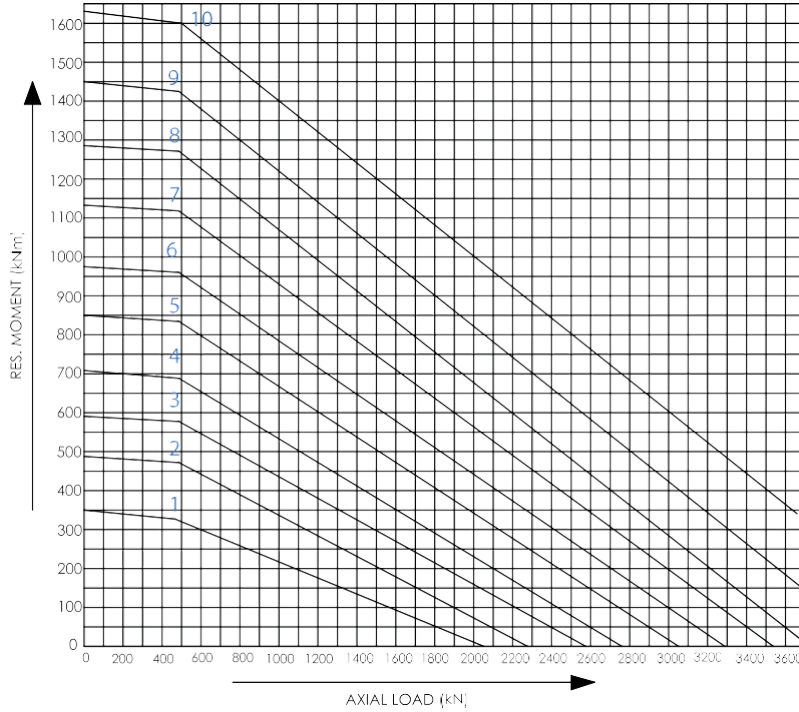

NO	COD E KOD	Weight / Ağırlık	Outer Dia. / Dış Çap	Inner Dia. / İç Çap	Ba II Track / Dönme Eksenli	Overall Height / Toplam Yükseklik	Outer Ring Height / Dış Ring Yükseklik	Inner Ring Height / İç Ring Yükseklik	Number Of Grease / Gresörülük Sayısı	External Bolt Circle Dia./Dış Ring Delik Eksenli	Internal Bolt Circle Dia./İç Ring Delik Eksenli	Number Of Bolt Holes (External)	Number Of Bolt Holes (Internal)	External Bolt Hole Dia./Dış Ring Delik Çapı	Internal Bolt Hole Dia./İç Ring Delik Çapı	Module / Modül	Number Of teeth / Diş Sayısı	Addendum Modification / Profil Kaydırma	Permissible tangential forces, normal / Müsaade edilen teğetsel kuvvet normal	Permissible tangential forces, maximum / Müsaade edilen teğetsel kuvvet, maksimum
		Kg	DL	DLi	H	Hi	G	Le	Li	ne	ni	de	m	z	xm	KN	KN			
1	0850I - 12B - 100	160	955	700	850	80	70	70	4	915	790	28	28	22	22	10	72		54	108
2	0950I - 12B - 100	180	1055	800	950	80	70	70	4	1015	890	30	30	22	22	10	82		54	108
3	1050I - 12B - 100	200	1155	900	1050	80	70	70	4	1115	990	30	30	22	22	10	92		54	108
4	1150I - 12B - 100	220	1255	1000	1150	80	70	70	4	1215	1090	36	36	22	22	10	102		54	108
5	1250I - 12B - 102	240	1355	1100	1250	80	70	70	6	1315	1190	36	36	22	22	10	112		54	108
6	1350I - 12B - 101	260	1455	1200	1350	80	70	70	6	1415	1290	42	42	22	22	10	122		54	108
7	1450I - 12B - 100	280	1555	1300	1450	80	70	70	6	1515	1390	42	42	22	22	10	132		54	108
8	1550I - 12B - 101	300	1655	1400	1550	80	70	70	6	1615	1490	42	42	22	22	10	142		54	108
9	1650I - 12B - 100	320	1755	1500	1650	80	70	70	6	1715	1590	42	42	22	22	10	152		54	108
10	1750I - 12B - 100	340	1855	1600	1750	80	70	70	6	1815	1690	42	42	22	22	10	162		54	108

İÇTEN DİŞLİ / INTERNAL GEAR

## Çift Sıra Küresel Bilyalı Yataklar / *Double-Row Ball Bearings*

DİŞLİSİZ YATAKLAR / *UNGEAR BEARINGS*

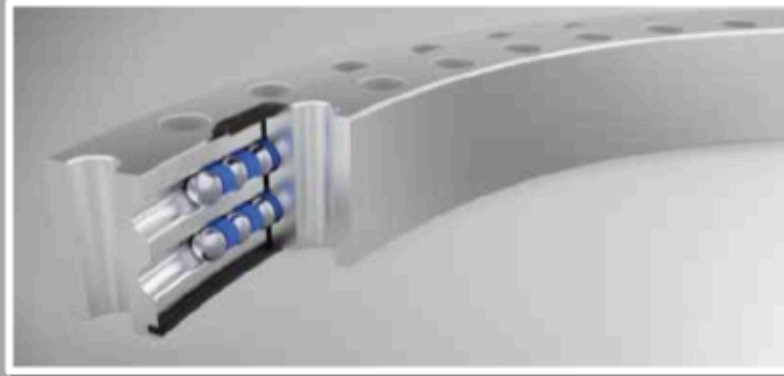

DIŞTAN DİŞLİ YATAKLAR / *EXTERNAL GEAR BEARINGS*

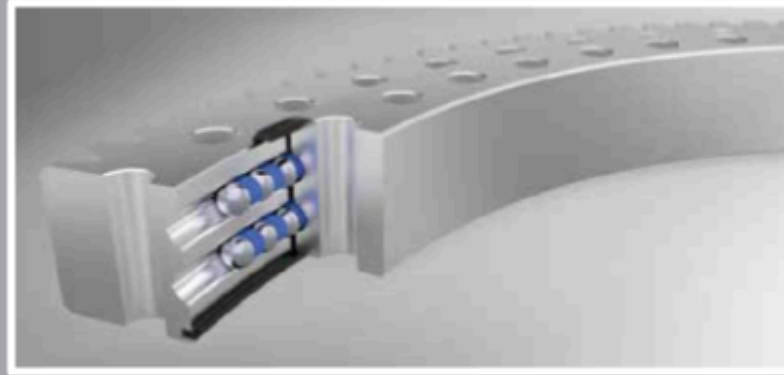

İÇTEN DİŞLİ YATAKLAR / *INTERNAL GEAR BEARINGS*

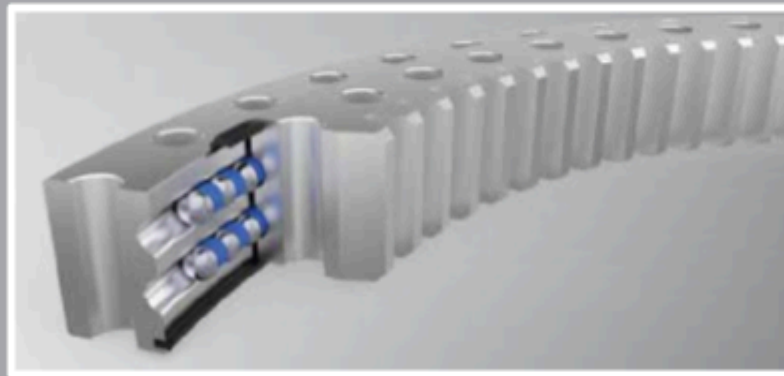

# Çift Sıra Küresel Bilyalı Yataklar / Double-Row Ball Bearings

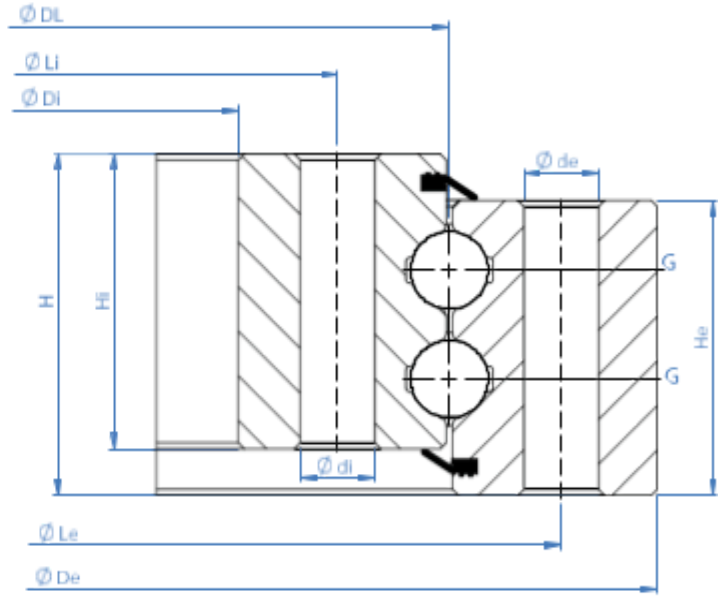
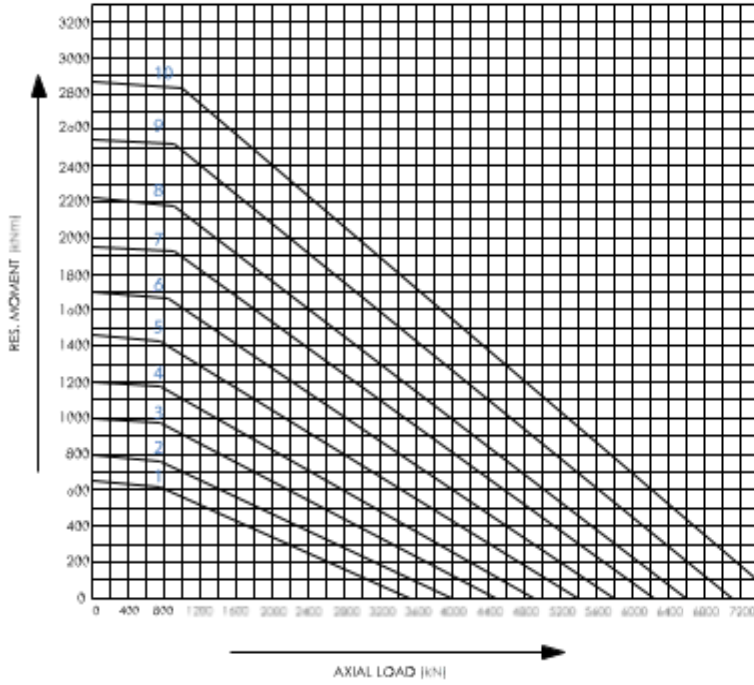

	Weight / Ağırlık	Outer Dia. / Dış Çap	Inner Dia. / İç Çap	Ball Track Dia. / Dönmeye Eksenim	Overall Height / Toplam Yükseklik	Outer Ring Height / Dış Ring Yükseklik	Inner Ring Height / İç Ring Yükseklik	Number of Grease / Gresörlük Sayısı	External Bolt Circle Dia. / Dış Ring Delik Ekseni	Internal Bolt Circle Dia. / İç Ring Delik Ekseni	Number of Bolt Holes (External) / Dış Ring Delik Ađedi	Number of Bolt Holes (Internal) / İç Ring Delik Ađedi	External Bolt Hole Dia. / Dış Ring Delik Çapı	Internal Bolt Hole Dia. / İç Ring Delik Çapı	Module / Modül	Number of teeth / Diş Sayısı	Addendum Modification / Profil Kaydırma	
CODE / KOD																		
NO	Kg	De	Di	DL	H	He	Hi	G	Le	Li	ne	ni	de	di	m	z	xm	
1	0821R - 12B - 200	165	935	715	821	102	92	92	4	893	753	36	36	21	21	-	-	-
2	0921R - 12B - 200	190	1035	815	921	102	92	92	4	993	853	36	36	21	21	-	-	-
3	1021R - 12B - 200	210	1135	915	1021	102	92	92	4	1013	953	36	36	21	21	-	-	-
4	1121R - 12B - 200	230	1235	1015	1121	102	92	92	4	1113	1053	36	36	21	21	-	-	-
5	1221R - 12B - 200	250	1335	1115	1221	102	92	92	4	1213	1153	36	36	21	21	-	-	-
6	1321R - 12B - 200	270	1435	1215	1321	102	92	92	4	1313	1253	42	42	21	21	-	-	-
7	1421R - 12B - 200	290	1535	1315	1421	102	92	92	4	1413	1353	42	42	21	21	-	-	-
8	1521R - 12B - 200	310	1635	1415	1521	102	92	92	4	1513	1453	42	42	21	21	-	-	-
9	1621R - 12B - 200	330	1735	1515	1621	102	92	92	4	1613	1553	42	42	21	21	-	-	-
10	1721R - 12B - 200	350	1835	1615	1721	102	92	92	4	1713	1653	42	42	21	21	-	-	-

7	6	5	4	3	2	1	N O	
13 91 E- 12 B- 20 0	13 35 E- -1 2B - 20 0	12 15 E- B- 20 0	11 17 E- B- 20 0	10 26 E- -1 2B - 20 0	09 41 E- 12 B- 20 0	08 21 E- 12 B- 20 0		
CODE / KOD								
67 0	40 0	36 0	36 5	32 0	25 0	21 5	K g	Weight / Ağırlık
16 05	15 00	13 80	12 90	12 00	11 00	98 0	D e	Outer Dia. / Dış Çap
12 08	12 15	10 95	98 5	91 0	83 5	71 5	D i	Inner Dia. / İç Çap
13 91	13 35	12 15	11 17	10 26	94 1	82 1	D L	Ball Track / Dönme Eksen
13 0	10 8	10 8	10 8	11 0	10 2	10 2	H	Overall Height / Toplam Yükseklik
11 6	9 8	9 8	9 8	10 0	9 2	9 2	H e	Outer Ring Height / Dış Ring Yükseklik
11 6	9 8	9 8	9 8	10 0	9 2	9 2	H i	Inner Ring Height / İç Ring Yükseklik
6	4	4	4	4	4	4	G	Number Of Grease / Gresörlük Sayısı
14 94	14 10	12 90	11 98	10 98	10 13	89 3	L e	External Bolt Circle Dia./Dış Ring Delik Eksen
12 80	12 55	11 35	10 35	95 4	87 3	75 3	L i	Internal Bolt Circle Dia./İç Ring Delik Eksen
4 8	4 8	4 8	4 8	3 6	3 6	3 6	n e	Number Of Bolt Holes (External) Dış Ring Delik Adedi
4 8	4 8	4 8	4 8	3 6	3 6	3 6	n i	Number Of Bolt Holes (Internal) İç Ring Delik Adedi
2 9	2 3	2 3	2 1	2 4	2 1	2 1	d e	External Bolt Hole Dia./Dış Ring Delik Çapı
2 9	2 3	2 3	2 1	2 4	2 1	2 1	d i	Internal Bolt Hole Dia./İç Ring Delik Çapı
1 2	1 0	1 0	1 0	1 0	1 0	1 0	m	Module / Modül
13 8	14 8	13 6	12 5	11 8	10 8	9 4	z	Number Of teeth / Diş Sayısı
1 2	-	-	10, 5	-	-	1 0	x m	Addendum Modification / Profil Kaydırma

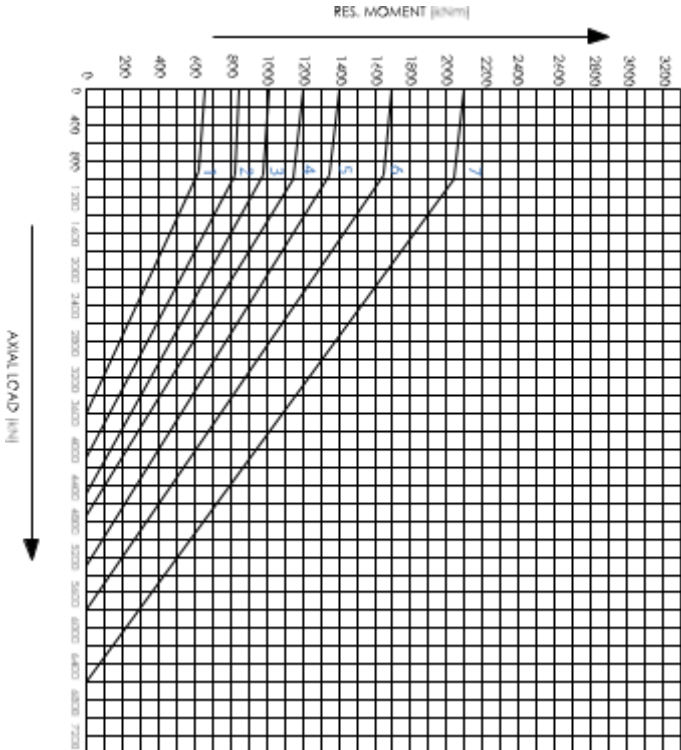
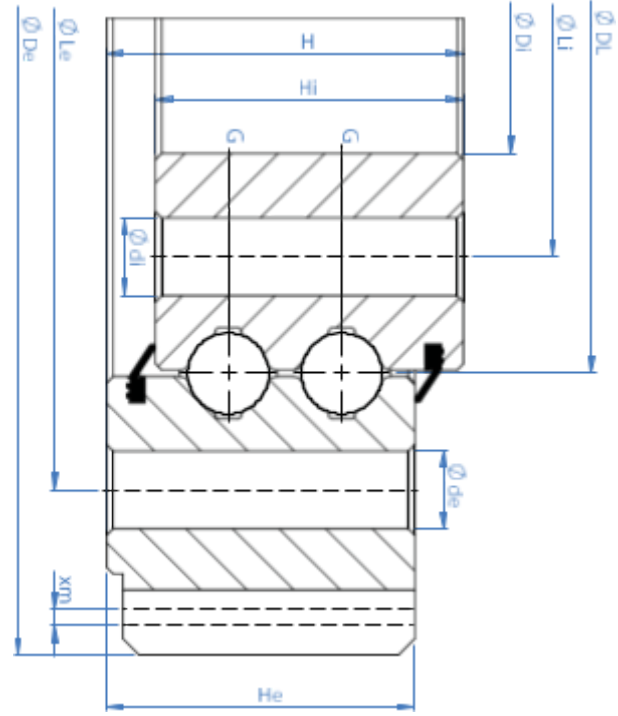



1 3 4	7 8	7 8	9 4	8 0	7 3	8 8	K N	Permissible tangential forces, normal / Müsaade edilen teğetsel kuvvet normal
2 6 8	1 5 6	1 5 6	1 8 8	1 6 0	1 4 6	1 7 6	K N	Permissible tangential forces, maximum / Müsaade edilen teğetsel kuvvet , maksimum

# Çift Sıra Küresel Bilyalı Yataklar / Double-Row Ball Bearings

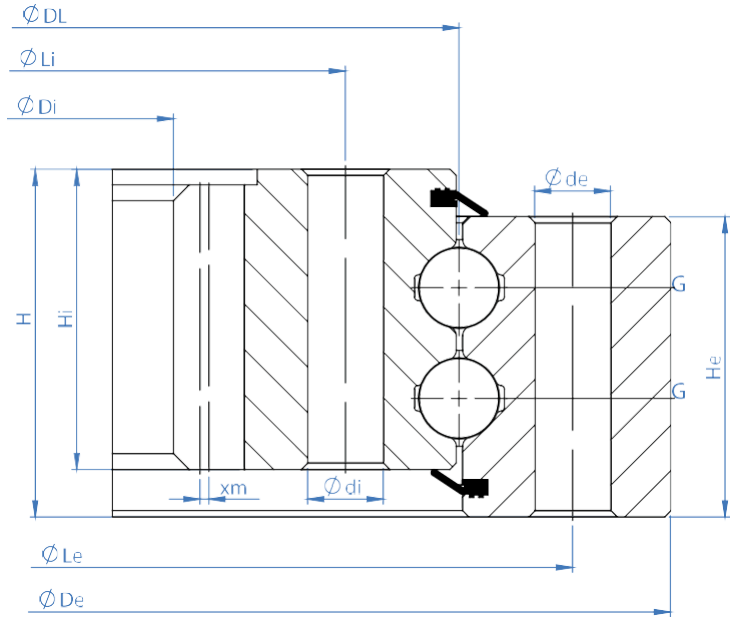
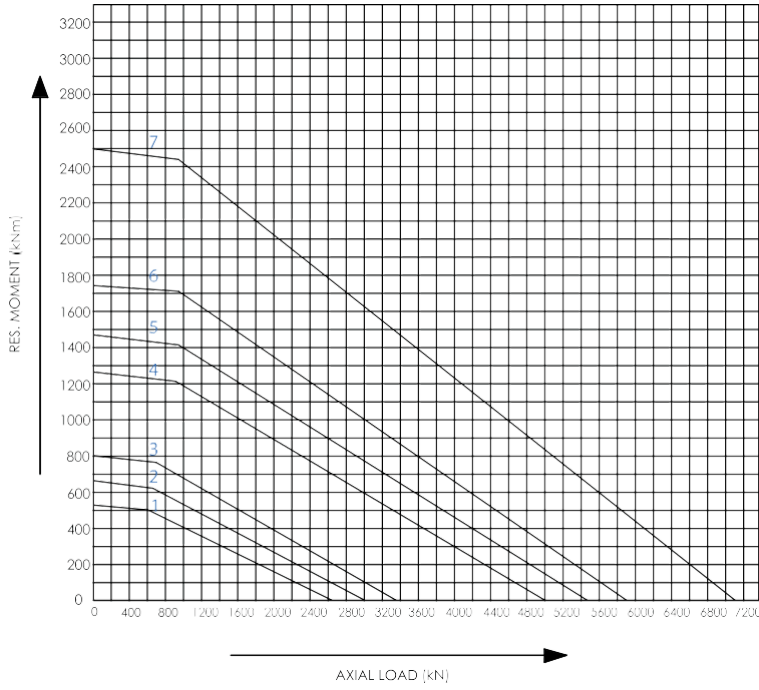

İÇTEN DİŞLİ / INTERNAL GEAR

NO	CODE / KOD	Weight / Ağırlık Kg	Outer Dia. / Dış Çap De	Inner Dia. / İç Çap Di	Ball Track / Dönme Eksenli DL	O vera II Height / Toplam Yükseklik H	Outer Ring Height / Dış Ring Yükseklik He	Inner Ring Height / İç Ring Yükseklik Hi	Number Of Grease / Gresörlük Sayısı G	External Bolt Circle Dia./Dış Ring Delik Eksenli Le	Internal Bolt Circle Dia./İç Ring Delik Eksenli Li	ne	ni	External Bolt Hole Dia./Dış Ring Delik Çapı de	Internal Bolt Hole Dia./İç Ring Delik Çapı di	İç Ring Delik Adedi m	Number Of teeth / Dış Sayısı z	Addendum Modification / Profil Kaydırma xm	Permissible tangential forces, normal / Müsaade edilen teğetsel kuvvet normal KN	Permissible tangential forces, maximum / Müsaade edilen teğetsel kuvvet, maksimum KN
1	0855I - 12B - 200	180	980	752	885	97	88	88	4	944	826	36	36	21	21	8	96		58	116
2	0982I - 12B - 201	200	1074	870	982	105	95	95	4	1035	936	40	40	22	17	8	111		63	126
3	1088I - 12B - 200	215	1175	962	1088	97	88	88	4	1134	1040	48	48	17	17	10	98		73	146
4	1144I - 12B - 200	300	1250	998	1144	110	100	100	4	1208	1080	36	36	21	21	10	100	8	91	182
5	1222I - 12B - 200	360	1345	1061	1222	110	100	100	4	1290	1150	40	40	22	22	10	108		79	158
6	1351I - 12B - 200	400	1470	1183	1351	110	100	100	4	1425	1270	40	40	23	23	10	120		79	158
7	1613I - 12B - 200	630	1750	1418	1613	125	110	110	4	1705	1525	40	40	25	25	12	120		110	220

## Tek Sıra Masura Yataklar / *Single-Row Roller Bearings*

### DİŞLİSİZ YATAKLAR / *UNGEAR BEARINGS*

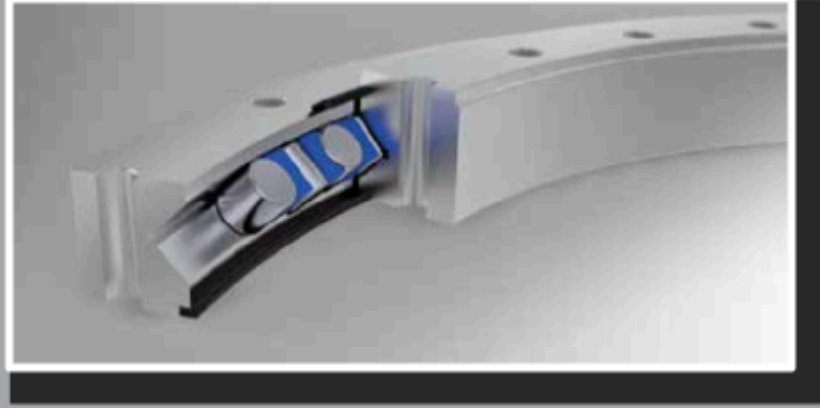

### DİŞTAN DİŞLİ YATAKLAR / *EXTERNAL GEAR BEARINGS*

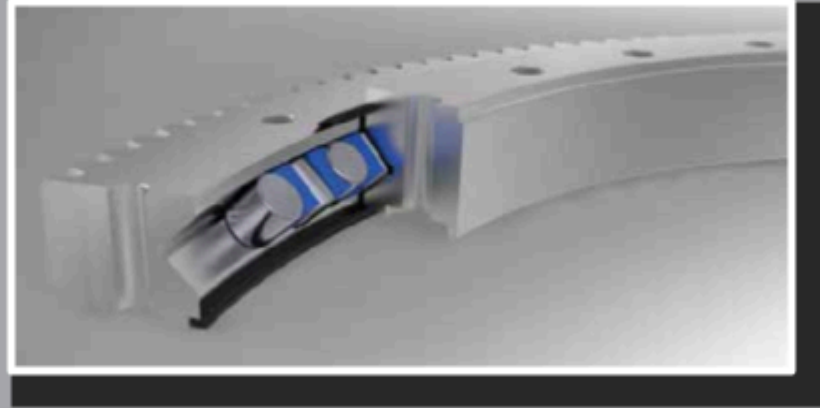

### İÇTEN DİŞLİ YATAKLAR / *INTERNAL GEAR BEARINGS*



# Tek Sıra Masura Yataklar / Single-Row Roller Bearings

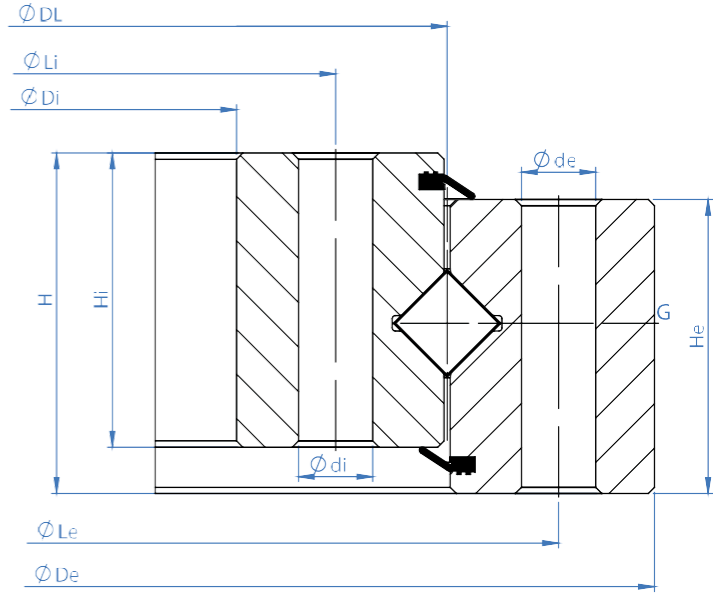
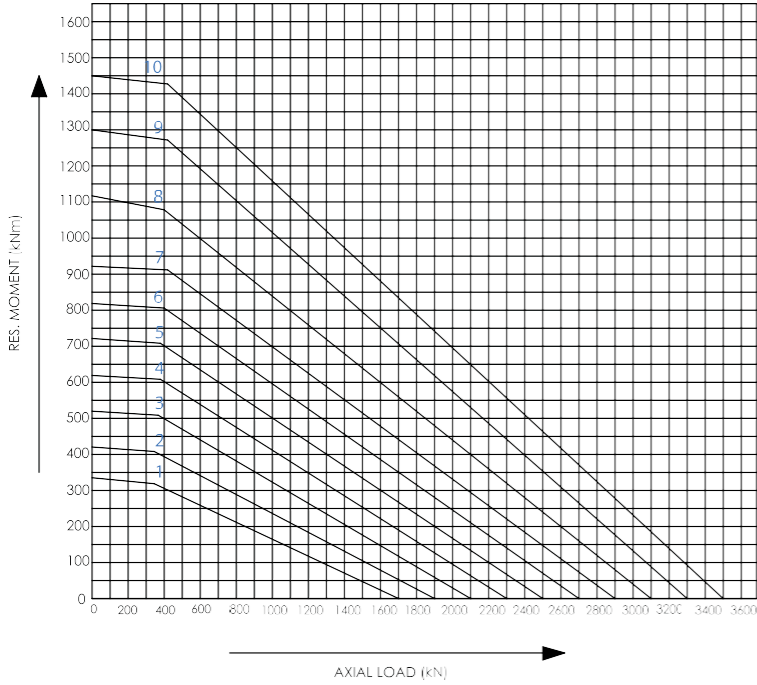

NO	CODE / KOD	Weight / Ağırlık Kg	Outer Dia. / Dış Çap De	Inner Dia. / İç Çap Di	Ball Track / Dönme Eksenini	$\varnothing$ verli Height / Toplam Yükseklik	Outer Ring Height / Dış Ring Yükseklik He	Inner Ring Height / İç Ring Yükseklik Hi	Number Of Grease / Gresörülük Sayısı G	External Bolt Circle Dia./Dış Ring Delik Eksenini	Internal Bolt Circle Dia./İç Ring Delik Eksenini	Number Of Bolt Holes (External) Dış Ring Delik Adedi	ni	External Bolt Hole Dia./Dış Ring Delik Çapı	Internal Bolt Hole Dia./İç Ring Delik Çapı	Module / Modül	Number Of teeth / Dış Sayısı z	Addendum Modification / Profil Kaydırma
1	0850R - 12R - 100	135	955	745	850	80	70	70	4	915	790	28	28	22	22			
2	0950R - 12R - 100	150	1055	845	950	80	70	70	4	1015	890	30	30	22	22			
3	1050R - 12R - 100	165	1155	945	1050	80	70	70	4	1115	990	30	30	22	22			
4	1150R - 12R - 100	180	1255	1045	1150	80	70	70	4	1215	1090	36	36	22	22			
5	1250R - 12R - 100	195	1355	1145	1250	80	70	70	6	1315	1190	36	36	22	22			
6	1350R - 12R - 100	210	1455	1245	1350	80	70	70	6	1415	1290	42	42	22	22			
7	1450R - 12R - 100	225	1555	1345	1450	80	70	70	6	1515	1390	42	42	22	22			
8	1550R - 12R - 100	240	1655	1445	1550	80	70	70	6	1615	1490	42	42	22	22			
9	1650R - 12R - 100	255	1755	1545	1650	80	70	70	6	1715	1590	42	42	22	22			
10	1750R - 12R - 100	270	1855	1645	1750	80	70	70	6	1815	1690	42	42	22	22			

# Tek Sıra Masura Yataklar / Single-Row Roller Bearings

NO	CODE / KOD			Di	DL	H		Hi	G	Le	Li	ne	ni			Module / Modül	Number Of Teeth / Diş Sayısı	Addendum Modification / Profil Ka	Permissible tangential forces, n	Permissible tangential forces, ma
				İç Çap	Ball Track / Dönme Eksen	Overa II Yükseklik		İç Ring Yükseklik	Number Of Grease / Greslilik Sayı	External Bolt Circle Dia./Diş Ring De	Internal Bolt Circle Dia./İç Ring Deli				m	z	xm	KN	KN	
1	0750E-12R-100	170	920	630	750	80	70	70	4	825	675	28	28	22	22	10	90		52	104
2	0850E-12R-100	192	1020	730	850	80	70	70	4	925	775	30	30	22	22	10	100		52	104
3	0950E-12R-100	215	1120	830	950	80	70	70	4	1025	875	30	30	22	22	10	110		52	104
4	1050E-12R-100	235	1220	930	1050	80	70	70	4	1125	975	42	42	22	22	10	120		52	104
5	1150E-12R-100	257	1320	1030	1150	80	70	70	6	1225	1075	42	42	22	22	10	130		52	104
6	1250E-12R-100	277	1420	1130	1250	80	70	70	6	1325	1175	42	42	22	22	10	140		52	104
7	1350E-12R-100	297	1520	1230	1350	80	70	70	6	1425	1275	48	48	22	22	10	150		52	104
8	1450E-12R-100	317	1620	1330	1450	80	70	70	6	1525	1375	48	48	22	22	10	160		52	104
9	1550E-12R-100	340	1720	1430	1550	80	70	70	6	1625	1475	48	48	22	22	10	170		52	104
10	1650E-12R-100	360	1820	1530	1650	80	70	70	6	1725	1575	48	48	22	22	10	180		52	104

## DIŞTAN DIŞLI / EXTERNAL BEARING

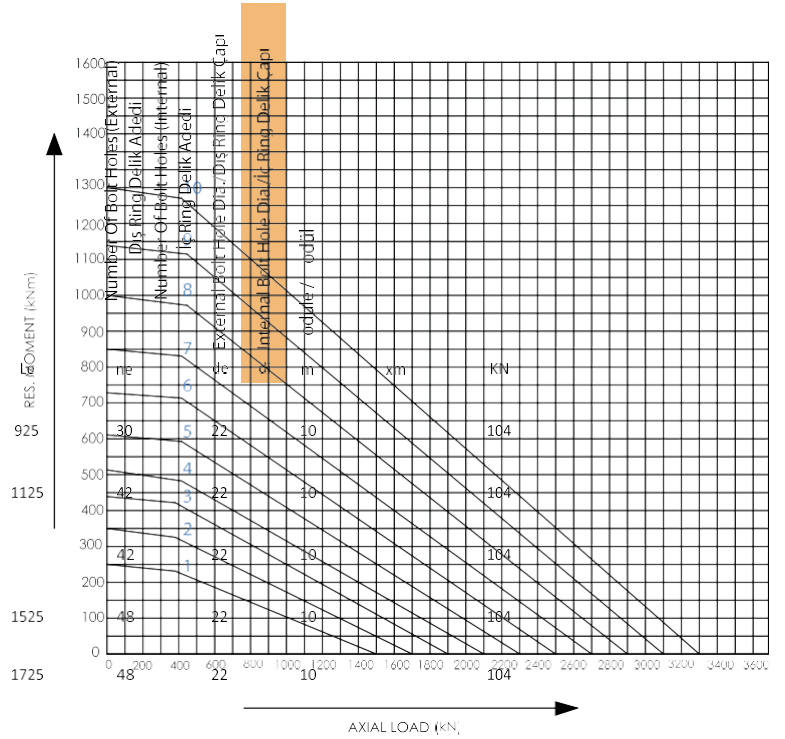
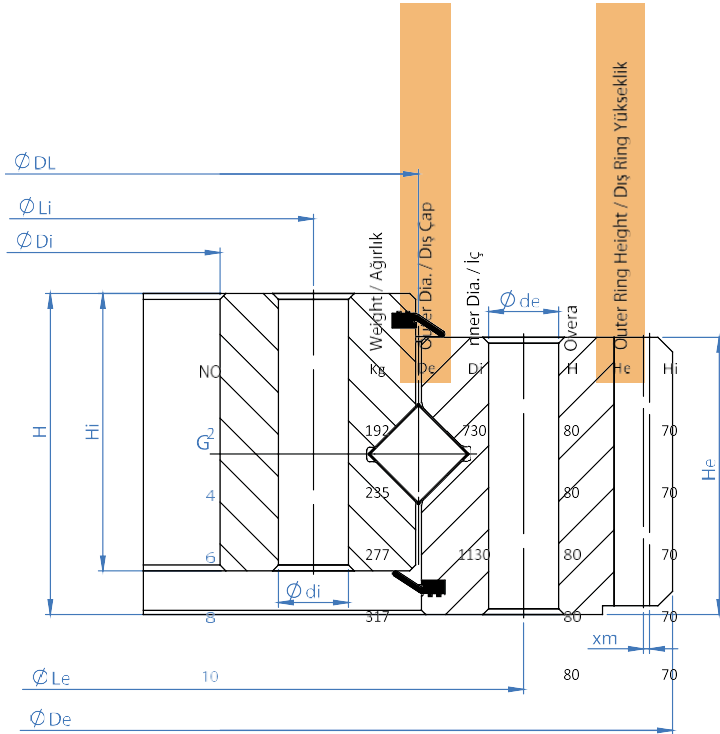



# Tek Sıra Masura Yataklar / Single-Row Roller Bearings

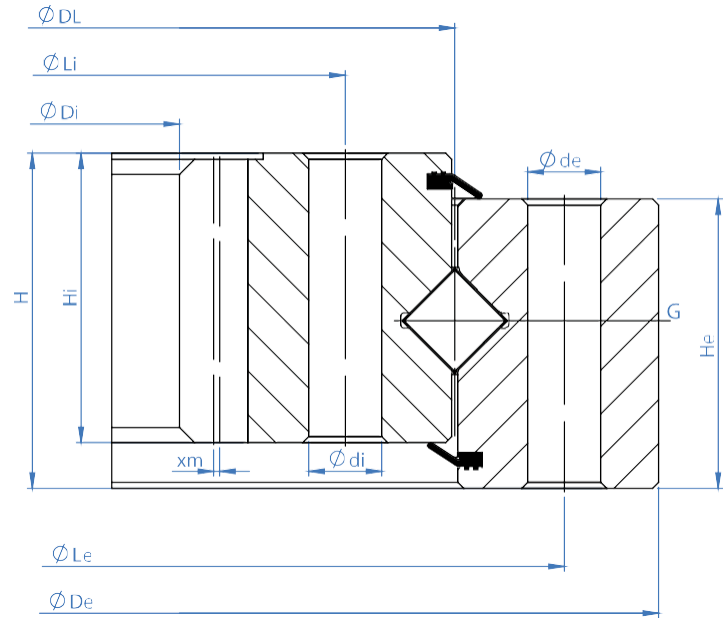
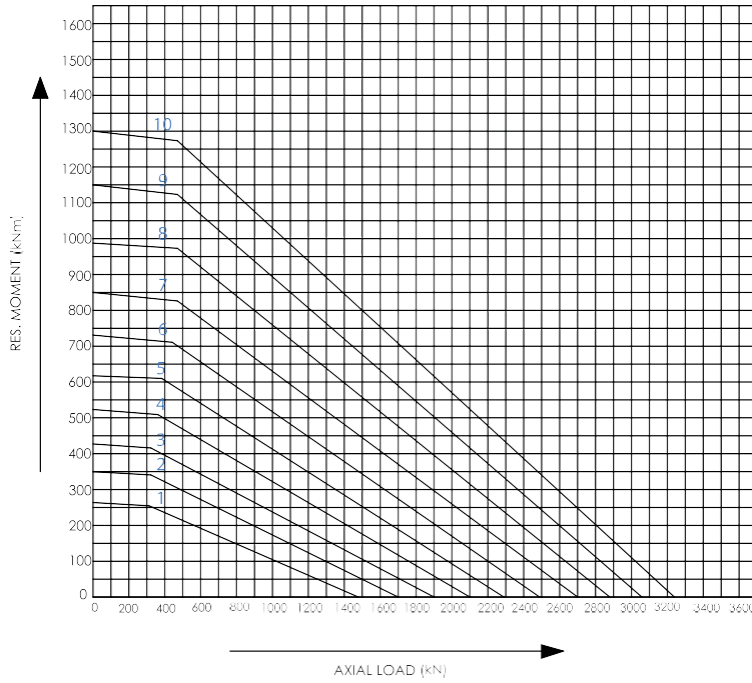

NO	CODE / KOD	Weight / Ağırlık Kg	Outer Dia. / Dış Çap De	Inner Dia. / İç Çap Di	Ball Track / Dönme Eksenli DL	Öyera II Height / Toplam Yükseklik He	Outer Ring Height / Dış Ring Yükseklik Hi	Inner Ring Height / İç Ring Yükseklik Hi	G	Number Of Grease / Greşirlik Sayısı	External Bolt Circle Dia./Dış Ring Delik Ekser Le	Internal Bolt Circle Dia./İç Ring Delik Ekseri Li	Number Of Bolt Holes (External) Dış Ring Delik Adedi	Number Of Bolt Holes (Internal) İç Ring Delik Adedi	External Bolt Hole Dia./Dış Ring Delik Çap de	Internal Bolt Hole Dia./İç Ring Delik Çapı di	Module / Modül B	Number Of Teeth / Diş Sayısı z	Addendum Modification / Profil Kaydırma xm	Permissible tangential forces, normal / Müsaade edilen teğetsel kuvvet normal KN	Permissible tangential forces, maximum / Müsaade edilen teğetsel kuvvet, maksimum KN
1	0750I-12R-100	160	870	580	750	80	70	70	4	825	675	28	28	22	22	10	60		54	108	
2	0850I-12R-100	180	970	680	850	80	70	70	4	925	775	30	30	22	22	10	70		54	108	
3	0950I-12R-100	200	1070	780	950	80	70	70	4	1025	875	30	30	22	22	10	80		54	108	
4	1050I-12R-100	220	1170	880	1050	80	70	70	4	1125	975	36	36	22	22	10	90		54	108	
5	1150I-12R-100	240	1270	980	1150	80	70	70	6	1225	1075	42	42	22	22	10	100		54	108	
6	1250I-12R-100	260	1370	1080	1250	80	70	70	6	1325	1175	42	42	22	22	10	110		54	108	
7	1350I-12R-100	280	1470	1180	1350	80	70	70	6	1425	1275	48	48	22	22	10	120		54	108	
8	1450I-12R-100	300	1570	1280	1450	80	70	70	6	1525	1375	48	48	22	22	10	130		54	108	
9	1550I-12R-100	320	1670	1380	1550	80	70	70	6	1625	1475	48	48	22	22	10	140		54	108	
10	1650I-12R-100	340	1770	1480	1650	80	70	70	6	1725	1575	48	48	22	22	10	150		54	108	

## Üç Sıra Masura Yataklar / Three-Row Roller Bearings

DİŞLİSİZ YATAKLAR / UNGEAR BEARINGS

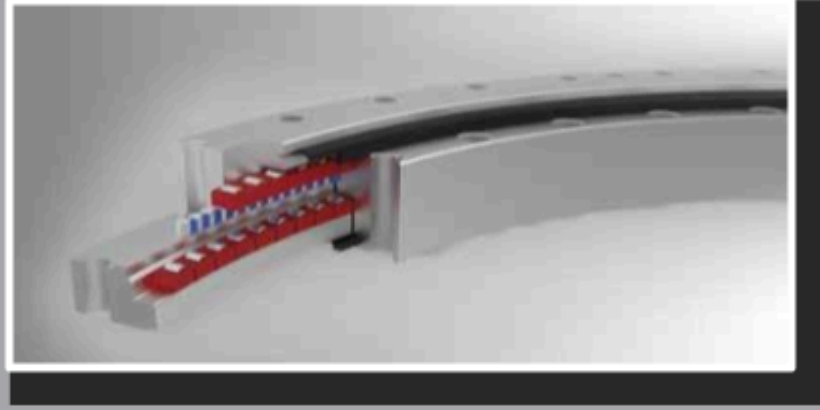

DIŞTAN DİŞLİ YATAKLAR / EXTERNAL GEAR BEARINGS

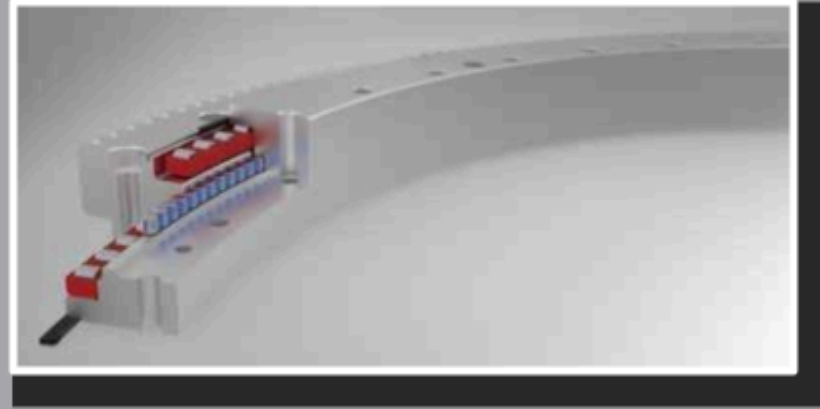

İÇTEN DİŞLİ YATAKLAR / INTERNAL GEAR BEARINGS

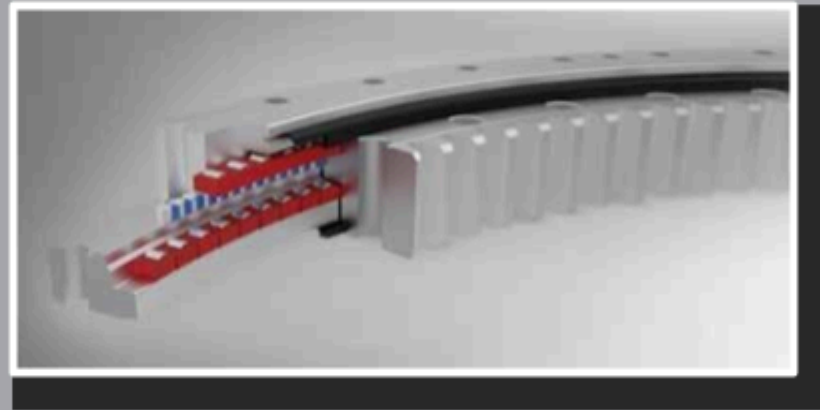



# 3 Sıra Masura Yataklar / Three-Row Roller Bearings

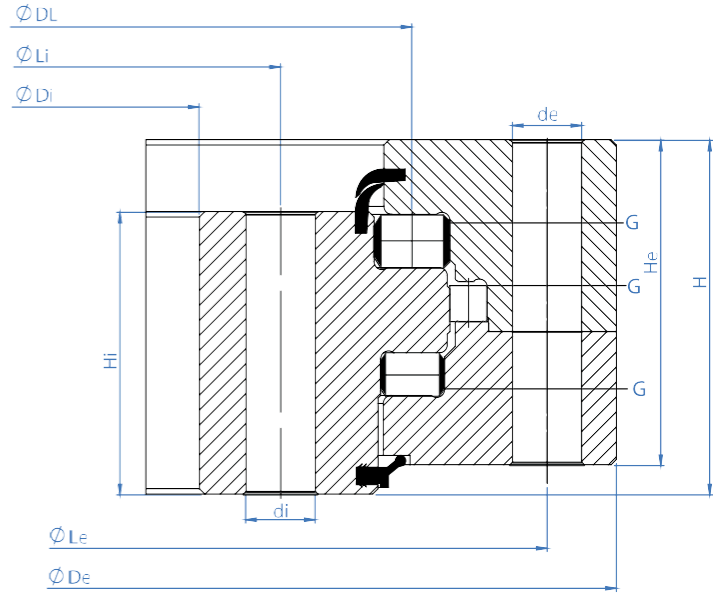
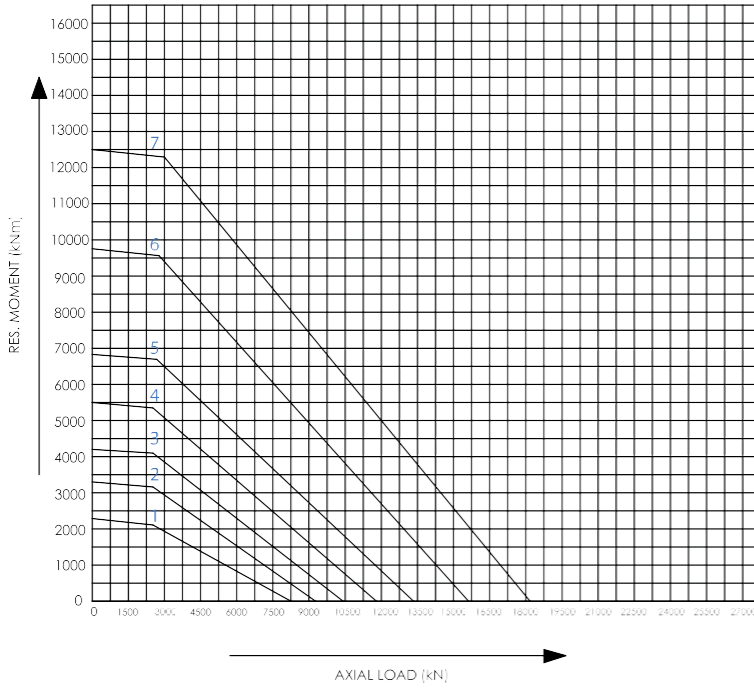

NO	CODE / KOD	Weight / Ağırlık Kg	Outer Dia. / Dış Çap De	Inner Dia. / İç Çap DL	Ball Track / Dönme Eksenine Dış Çap	Outer Ring Height / Dış Ring Yükseklik He	Inner Ring Height / İç Ring Yükseklik Hi	Number Of Grease / Gresörlük Sayısı G	External Bolt Circle Dia. / Dış Ring Delik Eksenine Li	Internal Bolt Circle Dia. / İç Ring Delik Eksenine Di	Number Of Bolt Holes (External) / Dış Ring Delik Adedi ni	External Bolt Hole Dia. / Dış Ring Delik Çapı de	Internal Bolt Hole Dia. / İç Ring Delik Çapı di	Module / Modül B	Number Of teeth / Dış Sayısı z	Addendum Modification / Profil Kaydırma X
1	1254R - 12R - 300	490	1407	1103	1254	132	106	123	9	1355	1155	36	36	26	26	
2	1444R - 12R - 300	598	1588	1293	1444	132	106	123	9	1500	1300	48	48	26	26	
3	1640R - 12R - 300	625	1785	1489	1600	132	106	123	9	1741	1542	48	48	26	26	
4	1872R - 12R - 300	700	2008	1600	1872	132	106	123	9	1960	1770	48	48	26	26	
5	2096R - 12R - 300	780	2232	1945	2096	132	106	123	9	2184	1994	54	54	30	30	
6	2528R - 12R - 300	900	2655	2100	2528	132	106	123	9	2600	2420	54	54	30	30	
7	2852R - 12R - 300	1055	2985	2701	2852	132	106	123	9	2930	2745	60	60	33	33	

# 3 Sıra Masura Yataklar / Three-Row Roller Bearings

## DIŞTAN DIŞLI / EXTERNAL GEAR

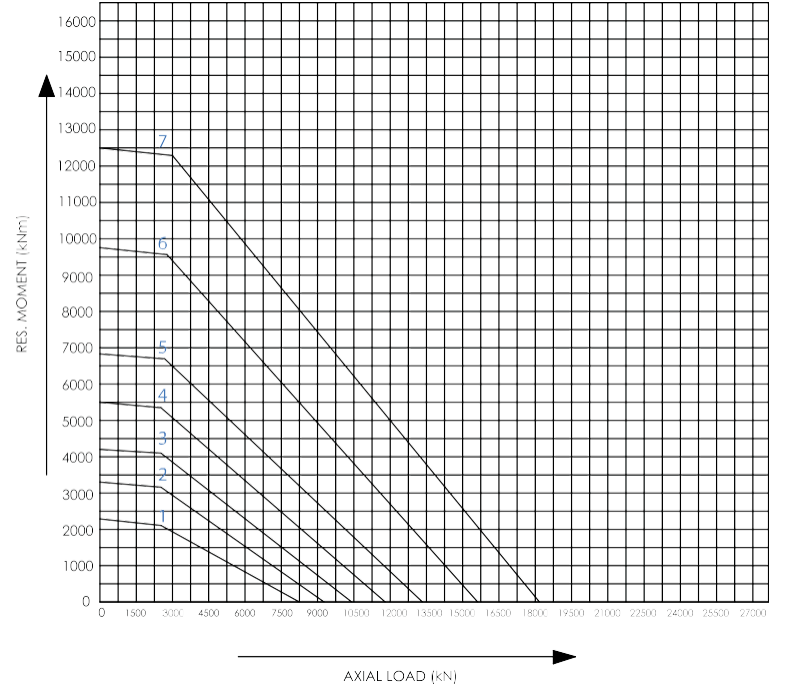
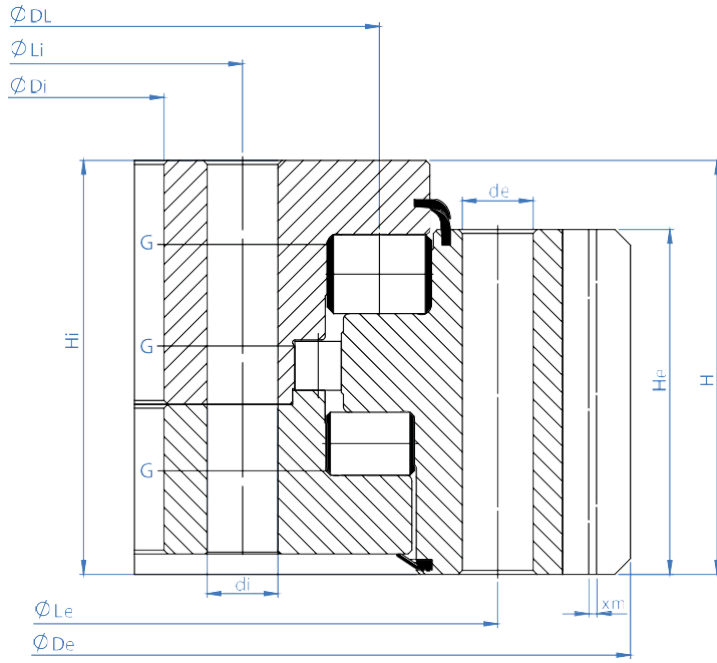

NO	CODE / KOD	Weight / Ağırlık Kg	Outer Dia. / Dış Çap De	Inner Dia. / İç Çap Di	Ball Track / Dönme Eksenli DL	O vera II Height / Toplam Yükseklik H	Outer Ring Height / Dış Ring Yükseklik He	Inner Ring Height / İç Ring Yükseklik Hi	Number Of Grease / Gresörlük Sayısı G	External Bolt Circle Dia./Dış Ring Delik Eksenli Le	Internal Bolt Circle Dia./İç Ring Delik Eksenli Li	ne	ni	External Bolt Hole Dia./Dış Ring Delik Çap de	Internal Bolt Hole Dia./İç Ring Delik Çap di	Diş Ring Delik Adedi Module / Modül/Number Of Bolt Holes (Internal) m	z	Addendum Modification / Profil Kaydırma xm	Permissible tangential forces, normal / Müsaade edilen teğetsel kuvvet normal KN	Permissible tangential forces, maximum / Müsaade edilen teğetsel kuvvet, maksimum / KN
1	1254E - 12R - 300	580	1461	1103	1254	132	106	123	9	1355	1155	36	36	26	26	12	119	6	122	244
2	1444E - 12R - 300	680	1652	1293	1444	132	106	123	9	1545	1345	48	48	26	26	14	116		118	236
3	1640E - 12R - 300	770	1848	1489	1600	132	106	123	9	1741	1542	48	48	26	26	14	130		118	236
4	1872E - 12R - 300	870	2080	1721	1872	132	106	123	9	1960	1770	48	48	26	26	16	128		135	270
5	2096E - 12R - 300	980	2304	1945	2096	132	106	123	9	2184	1994	54	54	30	30	16	142		135	270
6	2528E - 12R - 300	1170	2736	2377	2528	132	106	123	9	2600	2420	54	54	30	30	18	150		152	304

7	2852E - 12R - 300	1330	3060	2701	2852	132	106	123	9	2930	2745	60	60	33	33	18	168		152	304
---	-------------------	------	------	------	------	-----	-----	-----	---	------	------	----	----	----	----	----	-----	--	-----	-----

# 3 Sıra Masura Yataklar / Three-Row Roller Bearings

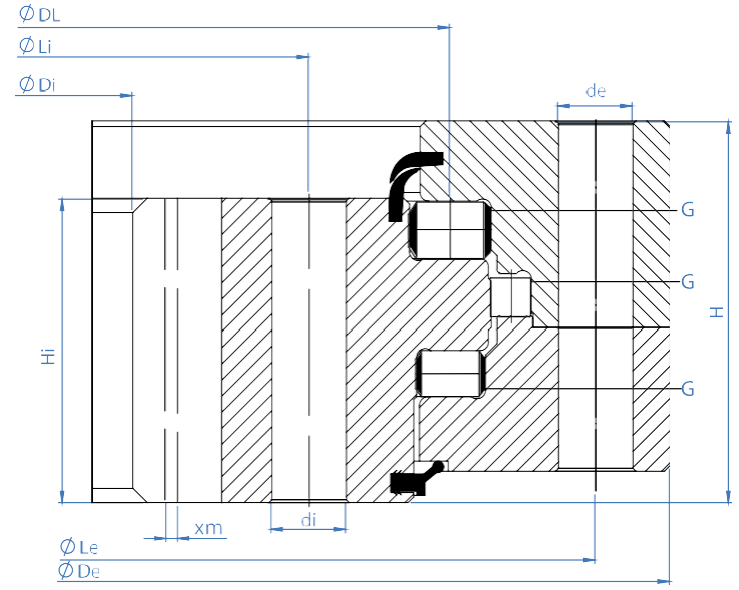
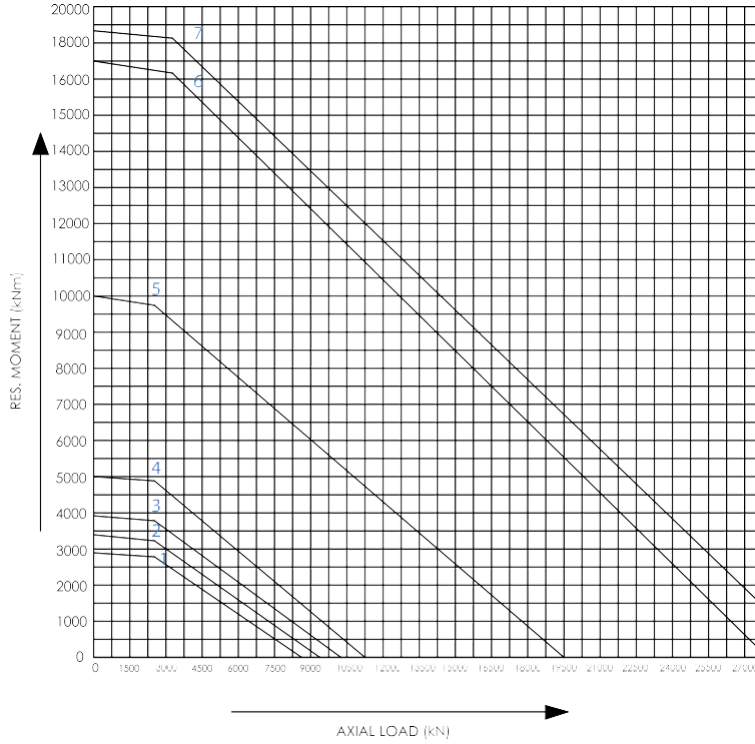

İÇTEN DİŞLİ / INTERNAL GEAR

NO	CODE / KOD	Weight / Ağırlık Kg	Outer Dia. / Dış Çap De	Inner Dia. / İç Çap Di	Ball Track / Dönme Eksenini DL	Overa II Height / Toplam Yükseklik H	Outer Ring Height / Dış Ring Yükseklik He	Inner Ring Height / İç Ring Yükseklik Hi	Number Of Grease / Gresörlük Sayısı G	External Bolt Circle Dia./Dış Ring Delik Eksenini Le	Internal Bolt Circle Dia./İç Ring Delik Eksenini Li	ne	ni	External Bolt Hole Dia./Dış Ring Delik Çapı de	Internal Bolt Hole Dia./İç Ring Delik Çapı di	Module / Modül / Diş Ring Delik Adedi m	Number Of teeth / Diş Sayısı z	Addendum Modification / Profil Kaydırma xm	Permissible tangential forces, normal / Müsaade edilen teğetsel kuvvet normal KN	Permissible tangential forces, maximum / Müsaade edilen teğetsel kuvvet , maksimum KN
1	1365I -12R - 300	490	1500	1190	1365	120	109	106	12	1456	1283	40	40	26	26	10	120	-5	102	204
2	1460I -12R - 300	540	1600	1275	1460	120	109	105	12	1550	1380	42	42	26	26	10	126	-17,5	101	202
3	1600I -12R - 302	700	1760	1372	1600	133	122	106	12	1700	1495	40	40	30	30	14	99	-7	143	286
4	1794I -12R - 300	880	1947	1552	1794	132	123	106	15	1895	1695	46	46	26	26	16	98	-8	163	326
5	2570I -12R - 300	1600	2754	2288	2570	151	138	119	28	2684	2435	72	72	33	33	16	144	-8	183	366
6	2800I -12R - 300	3270	3038	2460	2800	223	210	170	24	2960	2635	80	80	39	39	20	124	-10	328	657
7	3149I -12R - 301	2920	3368	2820	3149	181	172	139	28	3290	2995	56	56	39	39	20	142	-10	150	300



## Tel Yataklar / Wire Race Bearings

Üç telli masuralı yatak  
Three - wire race roller bearings

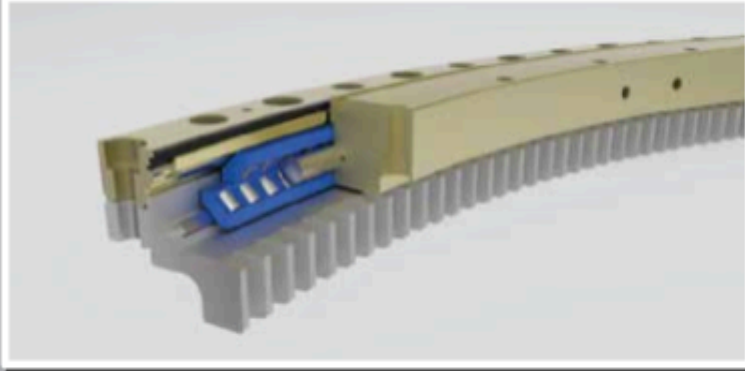

Üç sıralı telli masuralı yatak  
Three - row wire - race roller bearings



Tek sıra dört nokta temaslı telli bilyalı yatak  
Single - row four - point wire - race ball bearing



Çapraz masuralı telli yatak  
Cross - roller wire - race bearing



Üç sıra çapraz masuralı telli yatak  
Three - row cross roller wire - race bearing



Üç telli masuralı yatak  
Three - wire race roller bearing

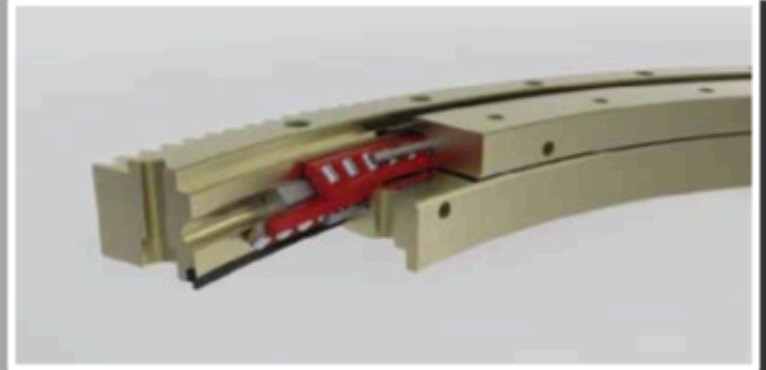

TİBET MAKİNA, tel yataklı rulman imalatı yapmaktadır. Tel yataklı sistemlerin en büyük avantajı yaklaşık olarak %60 daha hafif olmasıdır. Sürtünmenin az olması çok düşük değerlerde kalkış torkuna olanak sağlar. Tel yataklı sistemler çarpılmaya maruz kalmadığı gibi hafiflik, sınırsız malzeme seçeneği, korozyon direnci, düşük bakım maliyeti, şok ve ani yüklerle karşı yüksek elastisite dayanımı gibi önemli avantajlar sağlar. Bu uygulamaların tasarımı 100 mm ile 3500 mm arasındaki ölçülerde yapılabilir.



TİBET MAKİNA manufactures wire-race bearings. The most advantageous feature of our wire-race system is their weigh approximately 60% less. The rarity of the friction on the wires provide to work at very low torque values. This system does not distort as it has some main advantages, such as low weight, the unlimited material choice, resistance to corrosion, low maintenance, as well as it provides high elasticity in the case of shock and sudden loads. These practices can be designed between the sizes 100 mm and 3500 mm.





**FABRİKA / FACTORY**

Arbak İş Merkezi K.1 Manisa Yolu 4. km.  
35670 Emiralem / İZMİR - TURKEY  
Tel: (+90 232) 843 90 50 (pbx) - (+90 533) 651 42 96  
Fax: (+90 232) 843 90 54 - 843 87 66

**SATIŞ OFİSİ / SALES OFFICE**

Arbak İş Merkezi K.3 Manisa Yolu 4. km.  
35670 Emiralem / İZMİR - TURKEY  
Tel: (+90 232) 843 90 50 (pbx)  
Fax: (+90 232) 843 90 54 - 843 87 66

info@tibetmakina.com · www.tibetmakina.com.tr

**arbak**  
Grup